

TAPR PACKET STATUS REGISTER

In this issue...

President's Corner: TAPR's Future	1
Minutes of TAPR Board Meeting	2
APRS-TNC1 Kit Nears Completion	3
HSMW Microwave Radio	4
Power Supply for TEKK(tm)	
T-Net Mini/Micro Data Radios	10
APRSWXNET/CWOP Data and California Fires	14
Spread Spectrum Power Control	15

The President's Corner

TAPR's Future

By John Ackermann, N8UR

Although this year's DCC was a great success (see below), TAPR's board members had more to do than just put on a show. We scheduled a full day prior to the main event to define just what TAPR is today, and what we want it to become.

We were lucky to have Gerald Youngblood, AC5OG, spend the day with us as a facilitator. In addition to his work on the SDR-1000 Software Defined Radio, Gerald has worked as a consultant for startup companies, and was able to help us through the process of defining who we are, what we do, and what we want to accomplish.

It took 12 hours to get there (and we still have a lot



more work to do), but we ended up with a simple statement that we think defines our aspiration:

TAPR is a community that provides leadership and resources to radio amateurs for the purpose of advancing the radio art.

There's a lot buried in those twenty words.

First, we're a community. TAPR isn't me, or the Board - it's everyone who's a member. We're all in this together, and one of the great things about TAPR and the services we provide like mailing lists, PSR, and the DCC itself, is that we offer a way for hams who are interested in leading edge technology to share our knowledge, our skills, and our passion for Amateur Radio.

Second, we're leaders. Again, I'm not talking about the people on the PSR masthead, but the whole TAPR community. The technology that fascinates us today will be the mainstream in Amateur Radio a few years from now. We're the ones who will make that happen. Together, we are on the forefront of new

communications technology.

Third, we provide resources. The hardware we make available to the community, both as kits and finished products, is important, but we do much more than that and our contribution extends to publications, on-line resources, and other forms of knowledge sharing.

Fourth, we focus on the Amateur Radio community. That doesn't mean that we ignore non-hams who may benefit from what we do, but our core interest is always Amateur Radio.

Finally, everything we do is aimed at our goal of advancing the radio art. Those words should be familiar to you. The very first section of Part 97, the rules that govern Amateur Radio in the United States, lists five items as the "basis and purpose" of the Amateur Radio service. One of those reasons is "continuation and extension of the amateur's proven ability to contribute to the advancement of the radio art." That's what TAPR is all about. We don't disparage or minimize the importance of the other purposes of ham radio, but our energies are directed toward the technical goal of

advancing the Amateur Radio state of the art.

Now that we've defined ourselves, the Board is continuing the planning process. In addition to our on-line conversations, we're holding a series of conference calls to work through everything from our office operations, to how we decide on new projects and products, to how we most effectively get our message out to the ham community.

We're excited about the progress that we've made, and we'll be sharing more with you as we continue. In the meantime, what do you think about our definition? Does it match what you'd like TAPR to be? Remember, we're a community and your input means a lot to us. Please let us know what you think.

DCC

The 2003 DCC was by any measure a great success. Attendance was up after the post-9/11 downturn, the Proceedings were not only thick (in fact, the thickest ever!), but also thoughtful, and the buzz in and around the meeting rooms was exciting. My thanks go out to Steve (N7HPR) and Sheila Bible, John (W9DDD) and Laura Koster, Maty Weinberg (KB1EIB), Steve Ford (WB8IMY), and Stan Horzepa (WA1LOU), as well as the staff of the Hartford Airport Marriott, for making the show the success it was.

We had lots of papers relating to Software Defined Radios this year, and Matt Ettus, N2MJI, gave a Sunday Seminar devoted to SDR. From these presentations, it's clear the SDR is here now, and what was just a cool idea a couple of years ago is no longer a fantasy (remember what I said above about TAPR being leaders?). There's truly usable hardware out there now, with more to

come, and PC-based DSP software is maturing rapidly. Our chance to advance the radio art through this technology is here now, so you owe it to yourself to get up to speed on this exciting new paradigm for radio design.

I'm happy to announce that next year's DCC will be held in Des Moines, Iowa, from September 10-12, 2004.

Until next time,
73, John N8UR

###

Minutes of the TAPR Board of Directors Meeting

Windsor, Conn., September 18, 2003

Attendees:

John Ackermann, N8UR

Steve Bible, N7HPR

Byon Garrabrant, N6BG

Stan Horzepa, WA1LOU

John Koster, W9DDD

Doug McKinney, KC3RL

Brad Noblet, WA8WDQ

Darryl Smith, VK2TDS, by phone

Steve Stroh, N8GNJ

President Ackermann called the meeting to order at 8:15 AM EDT.

Guy Story, KC5GOL, resigned as secretary for personal reasons. President Ackermann asked Stan Horzepa to serve as acting secretary. Board of Directors will vote on the matter later. President Ackermann thanked Guy Story for his work.

Gerald Youngblood, AC5OG, conducted a brainstorming session concerning TAPR.

Steve Stroh motioned to certify the Board of Directors election results, i.e., the election of John Koster, Brad Noblet, and Steve Stroh. Doug McKinney seconded the motion. Motion was passed unanimously.

President Ackermann asked for nominations for secretary. John Koster nominated Stan Horzepa for secretary. After no further nominations, John Ackermann moved that Stan Horzepa be elected by acclamation. Stan Horzepa was elected by acclamation.

President Ackermann asked for nominations for treasurer. John Ackermann nominated Jim Neely for treasurer. After no further nominations, John Ackermann moved that Jim Neely be elected by acclamation. Jim Neely was elected by acclamation.

President Ackermann asked for nominations for vice president. John Koster nominated Steve Bible for vice president. After no further nominations, John Ackermann moved that Steve Bible be elected by acclamation. Steve Bible was elected by acclamation.

President John Ackermann excused himself and Vice President Steve Bible continued running the meeting and asked for nominations for president. Stan Horzepa nominated John Ackermann for president. After no further nominations, Steve Bible moved that John Ackermann be elected by acclamation. John Ackermann was elected by acclamation.

John Koster suggested that we should have more people running for the Board of Directors. A short discussion followed.

The live meeting adjourned at 7:45 PM EDT and will continue in electronic session.

###

APRS-TNC1 Kit Nears Completion

By Rich Carter, KE1EV, ke1ev@arrl.net

The APRS-TNC1 kit is an extension to the popular TAPR PIC-E kit. It uses a more powerful 16F876 microcontroller, adds an external memory chip, and provides a second serial port. One port is intended for connection to a host computer, while the other port is intended for connection to a peripheral device such as a GPS. Also included is a small breadboard area to allow hardware expansion using spare PIC I/O pins.

The kit is intended to provide hardware support for projects such as digipeaters and APRS stations. The kits will be delivered with diagnostic and bootstrap loader firmware pre-loaded on the PIC processor. After assembling the kit, the user will download application software from the TAPR web site. No external hardware is required to load the application. An ICD header is provided on the board for an optional low-cost in-circuit debugger.

Open source software will be provided with the kits. At the present time, one software application is under development. This software is currently in integration. It is written in C using the CCS compiler. It provides drivers for onboard hardware devices using a multi-threading technique. It implements a self-contained APRS station. This software both transmits and receives APRS packets. Position information is obtained from either non-volatile storage or an external GPS.

Packets are transmitted at a programmable interval using the MIC-E format. Received packets are filtered by call sign and message type. Those of interest are logged to external memory for later retrieval by a host computer application.

It also supports KISS operation including parsing sentences used for terminal configuration. Developers could expand the kit by adding external hardware and by modifying the supplied software to suit their needs.

As an example, the kit could be used to provide a control link to a remote repeater installation. This link could monitor repeater parameters, generating a status message at regular intervals. Example parameters might include temperature, supply voltage, and SWR. A second station at a control operator location could monitor this data stream and generate an alarm if parameters are out of range. The return data path could be used to control the remote repeater (e.g., switch antennas, reduce power, etc.).

Another example is a remote weather station. A barometric sensor could be added to the breadboard area. This datum could be combined with data from a one-wire weather station.

Another example is a sensor package for marine use. The NMEA sentence structure defines sentences for water temperature, wind speed and direction. These sentences could be combined

with GPS position information to form a weather report from a marine platform.

These are just a few of the uses for the kit that come to mind. The number of applications for the APRS-TNC1 kit is almost without limit.

Beta versions of the kit should be out before the end of the year. They will be distributed by TAPR. The first run kits will be sold at a reduced cost.

At the time these kits are released, the application software may still be in test. Host software may not be available at that time. These kits are intended for those who wish to write their own applications or participate in host software development.

Host software is software that runs on a host system such as a PC. It connects to the target and provides displays for things such as configuring the target or displaying target information. If you have interest in writing a host application, please contact the author at ke1ev@arrl.net.

At this time, we need a windows-based tool to manage non-volatile parameters (call sign, packet path, etc.). This tool would generate a hex file for download to the target board. It would also collect and display stored APRS messages from the target.

###

HSMM Microwave Radio

By John Champa, K8OCL, k8ocl@arrl.net, Gerry Creager, N5JXS, n5jxs@tamu.edu, Ron Olexa, KA3JIJ, ka3jij@callsign.net

HSMM stands for High Speed Multimedia microwave radio. It is not a specific operating mode, but rather a direction or driving force within Amateur Radio. The current developmental emphasis is adapting inexpensive off-the-shelf 2.4 GHz IEEE 802.11(r) equipment to operations under Amateur Radio service regulations, which in the US are covered by FCC Part 97.

HSMM microwave radio, although digital, it is *not* primarily a keyboard radio communication medium as in packet radio, as most amateurs presume. Amongst the capabilities of HSMM microwave radio most frequently used are digital voice (DV) and amateur digital video (ADV). Keyboard messages are possible, of course (chat mode) as in PSK31. Also, file transfers can be exchanged as in RTTY, but at significantly higher speeds! Plus, if there is a server on the HSMM microwave radio network, such operations as e-mailing, playing interactive games, and maybe even surfing the Internet by sharing a high-speed Internet connection with another amateur, are all possible. That is why it is called multimedia radio.

Although not perhaps the killer application, the HSMM driving force is emergency communications support. Imagine being at an emergency scene and being able to send live video images of what is happening back to everybody on the HSMM microwave radio network, back to the

EOC, and at the same time submitting a written report, long list of survivors, etc. All that is often needed is just your laptop computer, a special wireless local area network PCMCIA card with an external antenna jack (in HSMM jargon that is called a RIC, meaning a radio interface card), a small digital camera, and a short Yagi antenna. Except for the RIC and the little antenna, you may already have all this gear!

Background

A survey conducted by the ARRL Technology Task Force, of League members and other amateurs revealed that the number one Amateur Radio interest in new technologies was in high-speed digital radio networks. Some suggestions were:

- High-speed radio data links up to 20 Mega bits per second (Mbit/s)
- Ethernet at 2 Mbit/s on 10 GHz
- Encourage development of a high-speed amateur digital radio network
- High-speed digital audio/video radio

In January 2001, the ARRL Board of Directors voted unanimously that the ARRL should develop high-speed radio digital networks for the Amateur Radio service. The ARRL president appointed a group of individuals knowledgeable in the field from the international amateur community and industry. The group would report to the ARRL

Technology Task Force.

HSMM Working Group

The working group's first focus is on creating the microwave skills within the Amateur Radio community that are necessary to build and support portable and fixed high-speed radio based local networking. That's where amateurs interested in HSMM microwave radio can offer the most value to local RACES and ARES organizations, as well as to homeland security and other emergency communications efforts at the present time.

During Field Days and simulated emergency tests (SET), the HSMM Working Group encourages amateurs to hone their skills in doing rapid site surveys and deploying broadband HSMM microwave radio networks in the field. Some clubs put all their Field Day stations with their laptop-based logbooks onto one radio local area network (RLAN). This offered a tremendous competitive advantage. For example, if you are working 20M, you can see that the 15-meter band has just opened up because that tent's logging score is going through the roof. In another example, during the recent Midwest VHF-UHF Society (MVUS) Picnic 2003, an RLAN was used to link antenna test measurement results back to a printer. You get the idea. Use your imagination. The possibilities are almost without limit.

In this process of everyday use of HSMM

microwave radio, we are trying to understand how to enhance the reliability of our mainstream Amateur Radio network connections. Through various emergency communications training programs we will be trying to incorporate information to help local hams to be the people in their community who deploy these high-speed microwave radio networks on demand.

The primary means by which an amateur can become immediately involved today in HSMM microwave radio networking research is by adapting off the shelf IEEE 802.11 gear to operating within Amateur Radio regulations. This equipment is also known as WiFi equipment, and is commonly available at computer equipment retailers. As sold, the equipment operates in the 2.4 GHz ISM bands under Part 15 rules. The 802.11b standard (more on that later) was developed about six years ago for the purpose of providing a wireless alternative for office LAN installations. This wireless capability was to allow office LANs to be deployed without the expense and nuisance of running CAT5 cable to each computer. Due to the increase of homes with multiple computers, as well as rapidly falling price points for WiFi equipment, WiFi hardware has had a significant penetration into the home market place. In fact, in a recent CQ survey ("What You Have Told Us," CQ, September 2003, p.40), 8% of the respondents reported already using some kind of wireless networking, so there is already a growing understanding of the technology within the amateur ranks. A number of Livingston County amateurs already use WiFi in their homes.

The equipment as purchased has significant operating limits. Due to the Part 15 operating rules, power is severely curtailed. Remember, just like cordless phones, this hardware has to allow uncoordinated operation of many unlicensed devices with minimal interference. In addition, many users of this technology adopted it because it allowed unencumbered connectivity for a laptop computer. By nature of the fact that a laptop is battery powered, most client cards offer only a small fraction of the power authorized under Part 15 rules in order to maximize battery life.

Depending on your needs, as an amateur neither of these considerations is a limit on your use of the WiFi technology. While a system as sold may have a range of only 50 to 100 feet, proper setup of a system under amateur regulations can provide coverage far in excess of that distance. In fact, one of our HSMM Working Group's test networks, called the Hinternet in Livingston County Michigan, can easily do 5-15 miles ranges at speeds of up to 54 Mbit/s (half-duplex) using small mast-mounted dish antennas in conjunction with off-the-shelf consumer-grade hardware.

Getting Started In HSMM Microwave Radio

Getting operational with this equipment is a bit more complex than going to Universal Radio(r), buying an HF, VHF, or UHF rig and going home and connecting a key, microphone and antenna. Because this is data radio local area network (RLAN) equipment, it expects to be communicating with a computer, or more precisely with software running on a computer. So you first

must decide what interfaces you are going to need to connect to your computer. Luckily, equipment is available for all the standard computer interfaces: Ethernet, USB, and PCMCIA.

If you use a laptop in your station, get the PCMCIA card. We recommend the type with an external antenna connection.

If you have a PC, get the WLAN (Wireless LAN) adaptor type that plugs into either the USB port or the RJ45 Ethernet port. Select the one best suited to your computer and your experimentation.

This is the heart of your new microwave digital radio station. It is a computer-operated HSMM 2.4 GHz microwave radio transceiver and it will probably set you back about \$60-\$80. It is usually easier if you start off teaming up with another ham radio operator living nearby and do your initial testing in the same room together. Then as you increase distances going toward your separate station locations, you can coordinate using a suitable local FM simplex frequency. The most often-used HSMM microwave voice coordinating frequency is 446.00 MHz, the National Simplex FM Calling Frequency for the 70cm band

Go to the local OfficeMax (r), Radio Shack (r), ABC Warehouse (r), or other consumer electronics outlet and purchase some economical and readily available wireless local area network (WLAN) devices. We recommend that you select devices that state they comply with IEEE 802.11b and are WiFi compatible. Because these devices are made by numerous manufacturers each using different techniques to achieve the same thing,

there were initial complaints about interoperability between devices of different manufacture. An industry group known as the WiFi Consortium, was formed to provide testing and certification of 802.11b devices. If the equipment is WiFi certified, it will interoperate with any other WiFi certified equipment, thus easing your initial installation and troubleshooting by assuring that device compatibility is not the root cause of a start-up problem. These devices operate on 2.4 GHz band using direct sequence spread spectrum (DSSS) with CDMA modulation at speeds up to 2 Mbit/s and complementary code keying (CCK) modulation for speeds of 5.5 and 11 Mbit/s. Operating speed is automatically selected by the equipment based upon signal to noise and signal strength of the operating channel. These 802.11b devices are usually the least expensive, are the easiest to work with, and offer the good propagation.

For a slightly additional expense, purchase the newer IEEE 802.11g devices. 802.11g is a relatively new standard that increases the speed of the channel from 11 Mbit/s maximum to 54 Mbit/s maximum. They also operate on the same 2.4 GHz frequencies, but use a form of modulation called orthogonal frequency division multiplexing (OFDM) to achieve the higher data rates. OFDM requires significantly more signal strength and signal to noise ratio in order to achieve 54 Mbit/s throughput but appears to tolerate multipath effects caused by radio signal reflections better than CCK modulation, so it may offer better propagation characteristics in certain cases.

When purchasing your equipment, there are a few things to be aware of. First, make certain the supplied rubber duck antenna(s) are removable and/or there is an external antenna port. If the device does not have an external antenna connection, check Don Rotolo's (N2IRZ) article in the February 2003 CQ for details on how to modify the device. Second, look at the radio specifications for the device. The transmit power and receive sensitivity varies widely among devices. Try to buy a device with the best (highest power and lowest receive sensitivity) specifications. The best generally available equipment has 100 mW (20 dBm) transmit power and -93 dBm receive sensitivity at 11 Mbit/s, while the poorest specs are 25 mW (13 dBm) transmit power and -87 dBm receive sensitivity at 11 Mbit/s.

Radio at these frequencies behaves the same as radio at any other: a 6-dB power increase will double effective range. Here we're dealing with a 12 dB advantage of the higher performance equipment versus the lower. In a small Part 15 home WLAN the difference is probably not noticeable. For our purposes operating longer distances under Amateur Radio regulations, a 12 dB difference is critical, and can make the difference between successful experimentation and frustration and failure.

If the device does have an external antenna connection, then go to any issue of CQ Magazine and look up Nema Electronics(r), CableXperts(r), or other cable supply source and order an 18"-24" strain relief cable, also called a pig tail. Order

the type of pigtail needed for your device. It will probably cost less than \$20. If you purchased a PCMCIA card, the pigtail will have a strange looking miniature antenna connector at one end, and should have a normal N-series connector at the other.

The first thing you will need to do is install the device in your computer. If you are using a PCMCIA or USB device you will need to install drivers. If you are using a device with an RJ-45 Ethernet interface, no drivers are needed for the device, but there are drivers needed for the Ethernet port in the computer. Additionally, there will be a method to communicate with this device for configuration. The included directions will explain how to accomplish this.

After you load up the software drivers on your PC, you will have two choices for configuring the equipment: ad-hoc and infrastructure mode. For now, set the device for "ad hoc" mode, and set it to any channel between 2 and 5 (they're in the correct portion of the amateur band). If all is operating correctly, the two cards (yours and your buddy's) should see each other and set up a communication session. Once the cards are talking, you can share files between the two computers in the same manner as if the computers were hardwired together on a LAN.

Once you have the cards tested and know you have a connection between them, it's time to add the outdoor antennas and see what distances you can achieve between the two devices. Hook up any external commercial (e.g., Comet (r)) or home-brew

2.4 GHz antenna. Shop around where the AMSAT-OSCAR-40 guys buy their Mode-S antennas for some good designs. Keep in mind, the higher the gain of the directional antenna, the smaller the main lobe will be, so aiming a high gain antenna will be more critical than aiming a low gain one. Most 802.11 equipment has a utility included that shows signal strength and signal-to-noise ratio. Using this utility to monitor signal strength as you aim your antenna will be of great assistance in finding the optimal aiming direction. Remember these antennas are directional in both horizontal and vertical planes, so you have to carefully aim in both azimuth and elevation to get optimum signal at the receiver.

Another thing to keep in mind is coax. Coaxial cable losses at these frequencies are enormous. Don't even try to use RG8 cable to connect between the device and antenna. You will need to purchase the best coax you can afford in order to keep line losses minimized. In fact, the antenna coaxial cable will likely be the most expensive part of the entire station, as you will want to use the lowest loss type you can handle, e.g. LMR-400, etc.

That's all there is to it. Best of all, you may not have spent more than \$100 so far, depending on what antenna hardware you have around.

Now point your antennas at each other, and fire away. At these power levels there is not much concern for RF safety, but if you are using a high-gain antenna, it is recommended you avoid standing directly in front of the business end while on the air.

HSMM Identification Methods

Do remember that it's your responsibility to properly identify your station during use. In the mode you are presently in, the ad hoc or direct station-to-station mode, the most common technique is to simply ID in-mode, i.e. if you transmitting voice, simply speak your call sign into the microphone. If you are transmitting video, just hold a QSL card up to the camera. Or, you can send a ping containing your call sign. Remember that as long as the RIC is operating, even with no traffic, the system is transmitting!

Antennas

Depending on how close your ham buddy is to your location, how high and clear over the trees your antennas are (2.4 GHz doesn't go through trees very well), the quality of the coaxial cable you are using, and many other factors, you should be able to get several miles range. Remember, these HSMM microwave radio devices are truly QRP and run only about 30-100 mW of RF output, so be resourceful and experiment often with different antennas. Antennas are the easiest method of improving range. Each dB of antenna gain adds to the effective power and sensitivity of the radio. Let's assume you have a radio with 25 mW of transmit power. Attaching a 3-dB gain external antenna (assuming no line loss) will increase the effective radiated power to 50 mW. A 30-dB gain dish antenna will increase the effective radiated power to a full 25 Watts! Antennas at these frequencies can have large gains in small packages, and can be easily used to achieve large increases in coverage.

If your signals are not covering the path between you and the nearest other HSMM microwave radio station, then open a copy of any edition of the ARRL Handbook and read the sections on antennas, transmission lines and UHF propagation. Consider putting the antennas higher, getting or building higher gain antennas, using lower-loss coaxial cable, etc., until the link is achieved.

You may also find a way to mount you gear at the antenna, and avoid the expense and loss of coaxial cable, too. This is another reason to consider devices that have Ethernet output. Standard CAT5 Ethernet cable can be run up to 300 feet with no loss. In comparison, USB can only be run 9 feet without a signal booster being installed. By using an Ethernet-based device, it is easy to remotely mount the unit close to the antenna and run cheap CAT5 cable back to your computer.

Running Higher Power

Using higher power in HSMM microwave radio is a last resort. It is a sound operating practice to run the minimum power needed to maintain the communications. Be considerate of others who may be using the band, both amateur and non-amateur. Use only the minimum power needed for the link.

If the link analysis (see the link calculations portion of www.arrl.org/hsmm/) clearly indicates that additional power is required, then what is usually needed is a bi-directional amplifier (BDA). This is a super fast switching pre-amplifier/amplifier combination that is mounted at the

end of the antenna pigtail near the top of the tower or mast. A reasonably priced 2.4 GHz 1.8 watt output BDA is available from the FAB Corporation (www.fab-corp.com) specifically for HSMM microwave Amateur Radio experimenters. This additional power output should be sufficient for nearly all amateur operations, even those supporting emergency communications which may require more robust link signal margins than normally needed by amateurs. Because of strict Part 15 regulations prohibiting the use of such devices by unlicensed individuals, a copy of your amateur license will be required with your order and the shipment will only be made to the address in the FCC database.

HSMM Microwave Radio Repeaters

The next step up the functionality ladder is to add a “repeater” to your system. More properly called wireless hubs or access points (AP), this device will allow several Amateur Radio microwave stations to share the network (and all the devices and circuits connected to it). An 802.11b AP will sell for about \$100 and 802.11g AP for about \$140. The AP acts as a central collection point for traffic, and can be connected to a single computer or to a network. It can also be used to allow several amateurs to share one high-speed Internet connection. The AP is provided with an ESSID, which is the name it broadcasts. For our purposes, the ESSID can be set as your call sign, thus providing automatic, constant identification. To use an AP in your network, the computer users have to exit ad-hoc mode and enter infrastructure mode. Infrastructure

mode requires you to specify who the network the device belongs to. This is what the ESSID does: identify the AP to its users, so the users can find the home system they belong to. Set your computer device to recognize the ESSID you assigned to your AP.

The AP can also be used as one end of a point-to-point network. For example, if you wanted to extend a network connection from one location to another, you could use an AP at the network end and use it to communicate to a computer at a remote location.

Using an AP allows more features and security than provided by ad-hoc mode. For example, most APs provide DHCP service, so they will automatically assign an IP address to the computers connected to the network. In addition, they provide filtering that allows only known users to access the network.

What frequency do you set on the AP? The HSMM Working Group recommends to everyone that they avoid using channel 1 (center frequency of 2412 MHz). Use of this channel may cause interference to the AMSAT-OSCAR 40 satellite downlinks. The WG also recommends that Amateur Radio stations avoid the use of channel 6 (center frequency of 2437 MHz). This is the most common default frequency used by the majority (80 %?) of Part 15 unlicensed stations for wireless local area networks (WLAN). At present, the most popular frequency used by Amateur Radio microwave stations for HSMM research is 2427 MHz (channel 4).

Note: If you use an HSMM microwave repeater to share high-speed access to the Internet, don't forget Amateur Radio content restrictions, e.g. no porn, no commercial business e-mails, etc. Don't worry about pop-up ads. Pop-up ads, although a nuisance, are no more illegal than an ATV station transmitting an outdoor scene inadvertently picking-up a billboard in the station camera.

HSMM Software

For operating software, most amateurs are using Microsoft (r) NetMeeting collaborative software, which comes free with the Microsoft Windows (r) operating system. Other forms of open source groupware using Linux are also popular. Try using OpenH323 or Speak Freely. By connecting a microphone to the audio input of your soundcard, you can have digital voice QSOs. By connecting an inexpensive digital camera (\$20) you can do digital video QSOs. These are not the same quality as the usual ATV contacts, but the equipment is much less expensive! (HI)

HSMM Traffic

How do you keep Part 15 unlicensed traffic from accidentally using your Part 97 licensed HSMM network? A traffic separation technique that is considered acceptable involves the use of WEP (wired equivalent protection)...not for encryption, but for authentication. If you use this approach under Part 97, therefore, you must publish the WEP key. We recommend that you ask that your HSMM repeater's WEP key be published on the HSMM web page (www.arrl.org/hsmm/), or simply use the amateur common WEP key

already designated on that web page. Again, the WEP is used to avoid the accidental mixing of Part 15 and Part 97 traffic, i.e. authentication, NOT encryption. Another approach gaining in popularity with many HSMM microwave stations is the use of 44 domain IP (Internet Protocol) addresses, which are only available to the Amateur Radio service.

Proposed HSMM Network Infrastructure

The HSMM Working Group is following a systems engineering approach toward the development of a nation-wide Amateur Radio HSMM network, as directed by their ARRL charter.

Although the initial draft of the proposed HSMM Network Infrastructure, also affectionately known as the Hinternet, has not yet been approved by the HSMM Working Group and subsequently opened for public comment, we can discuss here some of its planned key provisions.

One key element of the infrastructure specification and design is linking fixed emergency communications (EMCOMM) sites in a metropolitan area that will be utilized in emergency settings. This entails fixed path links, accessible by the target endpoints solely. Another element of the infrastructure planning is creating an integrated network of these point-to-point links, so that they are useful. Having a link between two sites is wonderful, but not too useful when there are 20 sites that need to communicate. To achieve this linking, we anticipate using conventional Ethernet switches (not hubs!) to interconnect the wireless

devices at node points, and we incorporate good RF practice in spatial and frequency diversity (different channels, changes in polarization, good horizontal and vertical separation) to achieve multiple links from a single site. One consideration in *all* of these links: We are recommending high-gain dish-style antennas, rather than omni directional antennas at the node sites. These antennas are readily available for less than \$100 with antenna gains in excess of 20 dBi. Both horizontal and vertical polarizations are available from most manufacturers.

Not all sites will require “full bandwidth” links to them. To accommodate the “last mile” links where 2.4-GHz spread spectrum might not serve, other alternatives, such as high-speed packet (56 kbit/s, or modem-speeds) or the Icom D-Star(r) system might serve well. Other alternatives, such as Virtual Private Networks (VPNs) across the existing, wired Internet may offer routine interconnection, while not necessarily being EMCOMM-capable or acceptably redundant.

In linking over longer distances, infrastructure considerations are more challenging. Here, almost certainly, we will consider Internet VPN links between established metropolitan networks. But this is only the beginning. Exciting experimentation is already going on within the HSMM Working Group.

Recommendations

Amateurs of all license classes are encouraged, to get on the air with inexpensive HSMM microwave radio using 802.11 off-the-shelf gear operating

under amateur regulations. It is easy, low-cost spread spectrum microwave radio experimentation. For more details and for the latest developments on all these initiatives, check out the link to HSMM WG open reflector at Texas A&M University at <http://listserv.tamu.edu/archives/arrl-80211b.html> or send e-mail to n5jxs@tamu.edu.

Suggested Reading

Building Wireless Community Networks, by Rob Flickenger. The latest 2003 edition may be purchased from ARRL Publication Sales Department, 225 Main Street, Newington, CT 06111-1494, USA, Phone Toll-Free (US) 1-888-277-5289 (Outside US) +1-860-594-0355 (www.arrl.org/catalog/cathelp.html)

Biography

John Champa, K8OCL, is chairman of the American Radio Relay League (ARRL) Technology Task Force on High Speed Multimedia (HSMM) Radio Networking. He can be reached at Moon Wolf Spring, 2491 Itsell Road, Howell, MI 48843-6458, e-mail k8ocl@arrl.net.

Gerry Creager, N5JXS, is a research network engineer at Texas A&M University. He can be reached at 8610 Rosewood Dr., College Station, Texas 77845-5594, e-mail n5jxs@tamu.edu

Ron Olexa, KA3JII, is an independent telecommunications consultant, and can be reached at 4929 Gair Loch Lane, Gainesville, GA 30506, e-mail ka3jjj@callsign.net

Power Supply for TEKK(tm) T-Net Mini/Micro Data Radios

By Don Rotolo, N2IRZ, n2irz@worldnet.att.net

(Editor's Note: Don Rotolo, N2IRZ, is presenting the design, assembly, installation, and operating instructions here for the Amateur Radio community.)

(These instructions and illustrations are released into the public domain for non-profit Amateur Radio use by the copyright owner, Donald Rotolo, N2IRZ. Any other use, including but not limited to commercial use, is not permitted. Copyright (c)1994, Amateur Networking Supply and Donald Rotolo, N2IRZ. All Rights Reserved, including the rights of translation.)

Product Description

The ANS Power Supply for the TEKK T-Net series data radios is a DC-DC converter circuit with a 9.6-volt output. The supply is capable of providing up to 1.5 Amperes. The attached TNC-Radio cable is fully shielded for 9600-baud operation. The top cover is drilled for mounting the Model KS-900 (T-Net Micro) UHF data radio offered by TEKK, Inc. of Kansas City, MO (816) 746-1098.

This product is available both fully assembled and as a kit. For the kit version, begin with UNPACKING below, and for the fully assembled version, begin with RADIO ATTACHMENT.

Features

The power supply uses an integrated circuit power converter for reliable operation. The

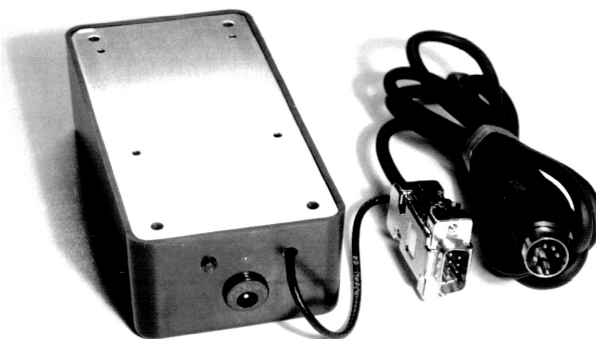

integrated circuit features foldback overload protection (reduces output voltage/current if overloaded) and thermal protection (output is interrupted if temperature exceeds limits). The LED power indicator is connected across the power supply's output, providing a reliable indication of proper operation. A sturdy predrilled case offers a convenient mounting system for the data radio, reducing clutter and the possibility of damage. High-quality, shielded TNC cable minimizes signal distortion and interference and allows high-speed operation. Solder-type connectors are used for improved reliability and easier repairs, if necessary. Rugged, solid-state design is vibration and shock resistant.

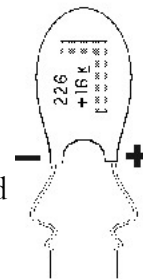

**Tantalum
Capacitor
Polarity**

Unpacking

Carefully unpack the Power Supply kit. Verify that the following parts are included:

- Printed Circuit Board
- 680 Ohm, 1/4w resistor, 5% (Blue-Gray-Brown-Gold)
- 221 Ohm, 1/4w resistor, 1% (Red-Red-Brown-Black-Brown)
- 1500 Ohm, 1/4w resistor, 1% (Brown-Green-Black-Brown-Brown)
- 22 μ F 16V Tantalum capacitor
- 24 AWG 2-conductor stranded zip cord, 16" long
- Coaxial DC power jack, 5.5 x 2.5 mm, chassis mount
- 0.1 μ F monolithic capacitor
- Plastic case with metal cover, predrilled
- Miniature LED, chassis mount, red
- 1/16-inch heat shrink tubing, 1/2 inch long
- Rubber grommet, 1/4"
- LM-317T voltage regulator IC, TO-220 case
- TO-220 finned heat sink, 5cm
- #4 x 1/2" machine screw with nut, for attaching the regulator IC to the heat sink
- Two sheet metal screws for attaching the heat sink to the case

- Felt tape, self-adhesive, 7/8" x 2"
- Plastic wire tie, 4 inches long
- Shielded cable with 5-pin male DIN connector attached
- DE-9 male connector, solder cup type
- Connector hood for DE-9, with hardware
- Four sheet metal screws, 3/8", for attaching top cover
- Four plastic spacers, 1/8" thick, to go between the radio and the top cover
- Coaxial DC power plug, 5.5 x 2.5mm, cable mount
- Velcro hook and loop tape, 1" x 2"
- Assembly and operating instructions

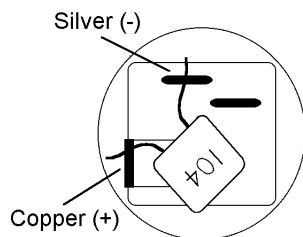

Assembly

Please! Read all of the assembly instructions before beginning. By understanding the entire process, your kit will assemble easier and function properly the first time!

1. Clean the copper (solder) side of the PC board with some fine steel wool. Insert the following components from the component side through the PC board and solder to the copper side, trimming excess wire leads:

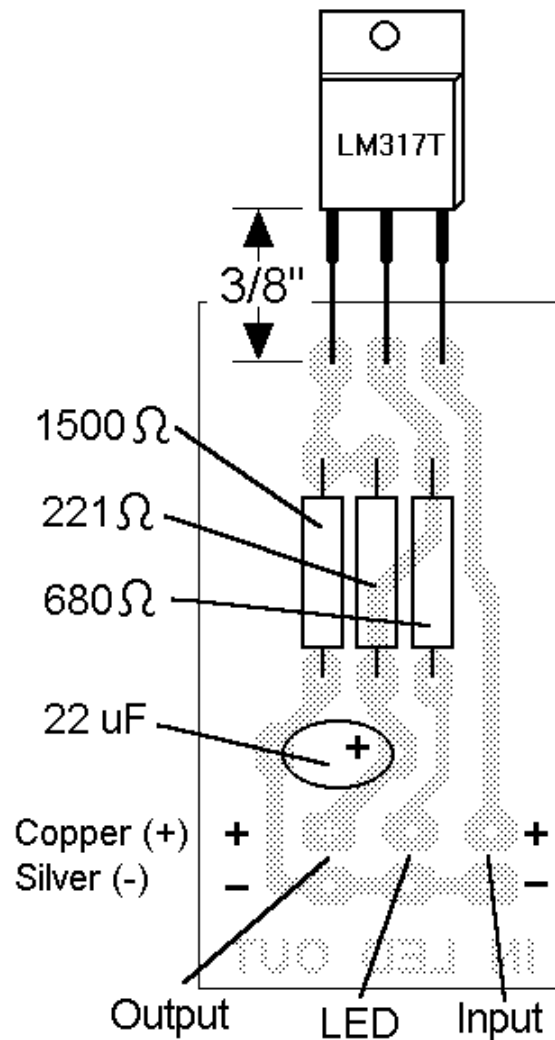
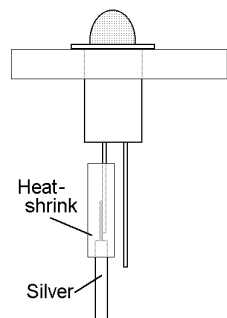

- 1500 Ohm resistor (Br-Gn-Bk-Br-Br)
- 221 Ohm resistor (Rd-Rd-Br-Bk-Br)
- 680 Ohm resistor (Bu-Gy-Br-G)

- 22 μ F capacitor (observe polarity !)
- Cut the 16" zip cord into two 8" pieces, then cut one of these into two 4" pieces. Unzip the ends for 3/4", strip 1/8" of insulation from each wire end (12 total) and tin them.
- Insert and solder the two 4" pieces of zip cord into the "IN" and "LED" positions on the PC board, being sure to insert the SILVER-colored wire into the MINUS (-) position.
- Insert and solder the 8" piece of zip cord into the "OUT" position on the PC board, again placing the SILVER wire into the MINUS (-) position. Trim the excess wire leads from all three sets of wire.

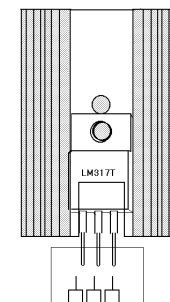

- Insert the LM317 regulator IC into the PC board so that the bottom of the plastic case is 3/8" above the PC board. Solder and trim excess wire leads.
- Remove the plastic nut from the power input jack. Install the 0.1 μ F capacitor onto the jack's terminals as shown, but don't solder them yet.
- Place the plastic nut, flat side out, onto the power "IN" wire and thread the wire from inside the plastic case through the predrilled 1/2" hole. Insert the zip cord wires into the input jack terminals as shown, paying attention to the copper and silver wire placement. Solder both terminals and trim any excess.
- Insert the power input jack into the 1/2"

hole and tighten the nut. Do not over tighten.

9. Insert the panel-mount LED into the 3/16" predrilled hole, from outside in. Place the 1/16" heat shrink tubing over the silver-colored "LED" wire and solder that wire to the shorter lead of the LED. Solder the copper wire to the longer lead. Slide the heat shrink tubing forward so that the solder joint is insulated and shrink it in place.

10. Apply a small amount of heat sink grease (not supplied) to the back of the LM317. A dab the size of a match head, in the middle of the IC, is about right.

Caution: Failure to use heat sink grease will cause the LM317 to overheat and become damaged.

11. Insert the #4 screw through the hole in the LM317 and then through the center hole in the heat sink. The LM317's leads should be over the notch in the heat sink, as shown.

12. Place the nut onto the screw protruding from the back of the heat sink and tighten firmly.

13. Place the heat sink against the back of the plastic case and fasten it with the two screws provided. The LM317 should face upwards.

14. Place the self-adhesive felt tape over the two heat sink screws as shown.

PLACE FELT TAPE TO COVER BOTH SCREWS COMPLETELY

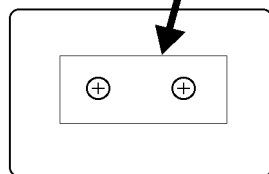

Caution: The LM317

tab, the metal heat sink, and the fastening screws are *not grounded*, but are connected directly to the power supply's output voltage. If any of these items contact ground, the smoke will be let out of the circuit and it will cease to function!

15. Insert the end of the long power output (OUT) wire through the grommet from inside the plastic case.

16. Place the 4" wire tie around the power output wire where it passes through the grommet as shown. Pull the output wire about 1/2" back into the case (to leave some slack) and position the wire tie against the grommet in the front panel.

Tighten the wire tie firmly around the wire (this is the strain relief for the power output wire). Trim the excess from the wire tie.

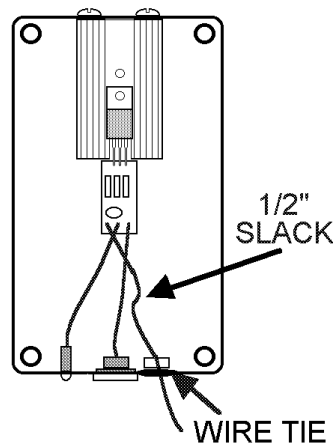

17. Cut the cable with DIN plug approximately 36 inches from the DIN plug. This can be made shorter or longer if desired, however, longer lengths are less desirable because signals passing through the wire are distorted more. Discard the excess wire. Remove 3/4" of the black outer insulation from end of the DIN cable. Be careful not to nick the shielding wire strands.

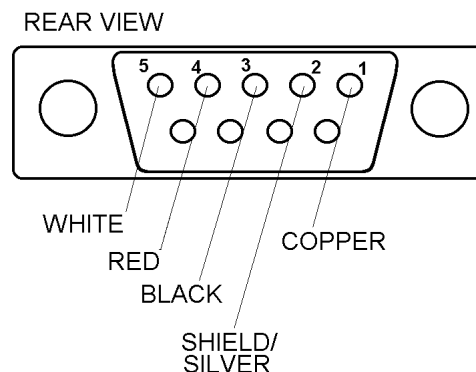

18. Separate the four insulated wires from the bare copper shielding strands. Collect a small bunch (approx. 15 strands) and twist them together to form a "tail". Cut off the remaining strands as follows: Holding the tail, pull the black insulation away from the end for approx. 1/4", then cut the loose strands. The insulation will return to its original position, covering the cut strands. Tin the bare copper tail.

19. Strip 1/8" of insulation from the black, red and white (or clear) wires. The yellow wire is not used. Tin the stripped ends.

20. Solder the wires to the DE-9 male connector as follows:

- White (or clear) Pin 5
- Red Pin 4
- Black Pin 3
- Shield tail Pin 2 (see illustration)
- 21. Solder the

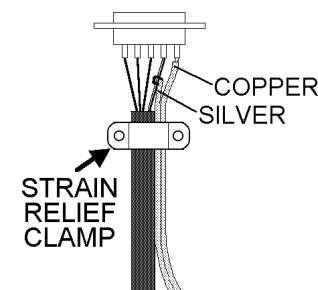

copper-colored output wire to pin 1 of the DE-9 connector. Wrap the silver-colored wire around the shield tail of the DIN cable and solder.

22. Install the strain relief clamp from the DE-9 hood onto both cables as shown. Use the two short screws and pre-threaded clamps provided with the hood. Be sure to avoid pinching the power output cable inside the clamp. Use the hood shell to determine the clamp's exact position, allowing for 1/16" of slack.

23. Assemble the hood around the DE-9 connector: Place both halves over the connector and snap together. Install the long fully threaded assembly screws through the holes and install the nuts for one turn. Then, place the washer clips onto the half-threaded fastening screws and insert them both through the holes. Separate the two halves slightly and the screws should pass through easily - if not, loosen the assembly screws more. With the two halves pressed together again, the fastening screws should be able to turn, but be held captive. Tighten the assembly screws, but don't over tighten.

24. Before connecting the radio, verify that the output voltage is 9.6 volts (+/- 0.2 volts), and that the pins of the DE-9M connector are connected properly (use an Ohmmeter and the schematic).

Radio Attachment

Before placing the power supply in service, attach the data radio. After attaching the radio to the top plate, attach the top plate to the power

supply housing, using the four sheet metal screws (supplied). Do not over tighten.

T-Net Micro

The top cover is drilled to accept the T-Net Micro's four mounting studs. To attach the radio, first remove the small nuts and lock washers from the bottom of the radio, being careful not to lose them. With the radio turned so the studs face upwards, drop one 1/8" plastic spacer (supplied) over each stud. The spacers are for better air circulation and cooling. Slide the power supply's top plate over the studs with the studs farthest from the antenna connector going into the holes closest to the end of the plate as shown. The antenna connector should not hang over the edge of the top plate. Place a lock washer and nut over each stud and tighten.

T-Net Mini

Using the small piece of Velcro brand hook and loop fastener (provided), attach the T-Net Mini to the top cover. Please allow at least 24 hours for the adhesive on the Velcro to set before placing any strain on it.

Connection

Plug the male DE-9 connector of the attached TNC-Radio cable into the receptacle on the data radio and tighten the captive fastening screws. Plug the male 5-pin DIN connector into the RADIO connector on the back of the TNC (see note below). Attach a suitable antenna to the radio.

The power supply requires a fused, filtered,

noise-free source of 12 volts DC nominal. The power input connector is a standard TNC type coaxial DC power jack (supplied), 5.5mm OD x 2.5mm ID, with the center pin positive. When a power source is connected to the input jack, the red LED should glow indicating output voltage is present. If it does not glow, disconnect power immediately and verify proper voltage and polarity.

When using an auxiliary modem, e.g., for 9600 baud, it is preferable to use the TNC's 5-pin DIN jack for radio connection. This simplifies separation of the radio from the TNC for service, adjustments, etc. and allows interchangeability through the use of a standard connector. Since it is virtually impossible to solder wires directly to the back of a PC-mount DIN jack, the solder pads on the bottom of the TNC's PC Board are used. Simply connect the TXAudio and RXAudio wires from the modem to the proper pin of the DIN jack, and remove the DC blocking capacitors from the TNC. These blocking capacitors, between the DIN jack and the TNC's internal modem, are in series with the RX and TX audio circuits. In a PacComm Tiny-2/Micropower-2, these are C7 and C8. In an MFJ-1270, they are C34 and C35. You should verify the correct components before removing anything! Of course, you can also remove the DIN plug from the power supply's cable and solder these wires directly to the auxiliary modem's wiring, as directed in the modem's instructions.

The power supply cabinet may be drilled to promote better heat dissipation if desired. Simply drill a few 1/4" holes near the top and bottom of the plastic case sides. However, in our experience, this isn't really necessary. Although an oversized heat sink is used, it is advisable to use a small cooling fan (which would help the radio, as well) when ambient conditions may be expected to exceed 110°F (40°C).

Specifications

Input Power: 11.5 to 16 Volts DC, 5.5 x 2.5mm coaxial jack, center pin +

Output Power: 9.6 volts DC @ 1.5 Amps

(Max.), 1.0 Amps continuous @ 70°F

Filtering: 22 mF tantalum capacitor for output, 0.1 mF Mylar capacitor for input

Indicator: Red mini-LED, connected across output

Size: 5 x 2-5/8 x 1-5/8 inches, excluding TNC-Radio cable.

Cable: 5-pin DIN to DE-9M, 3 feet long, fully shielded.

Housing: Black Polystyrene with Aluminum Cover

Schematic Diagram

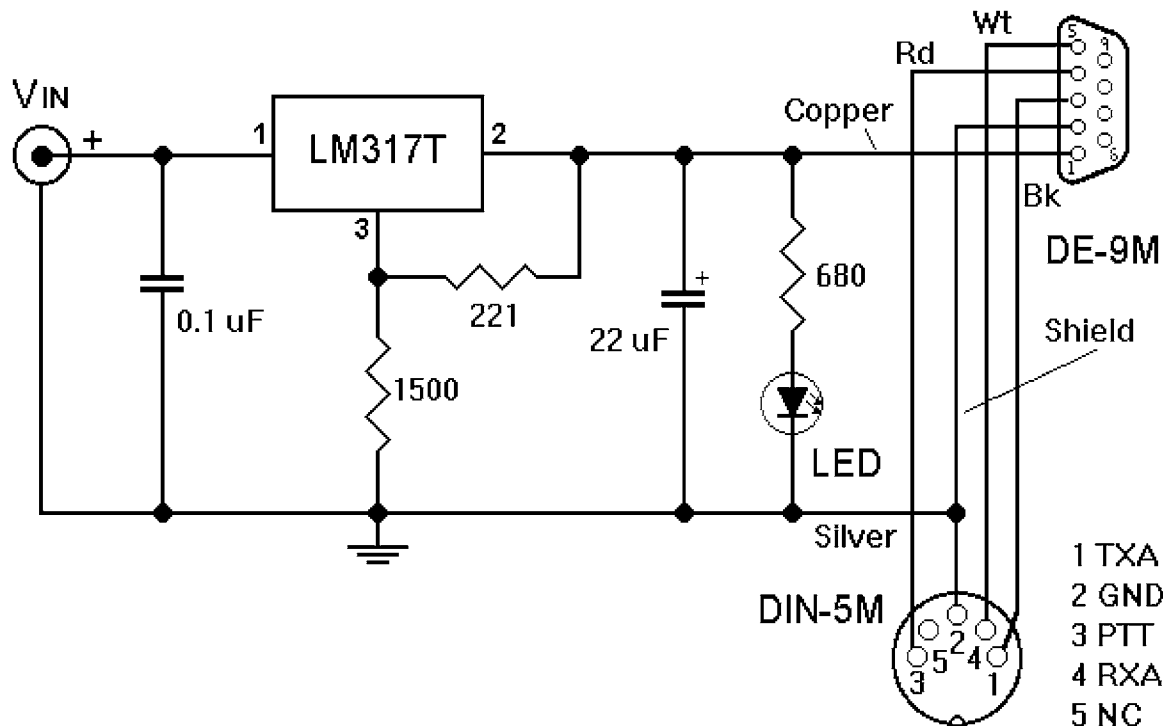

**APRSWXNET/
CWOP Data and
California Fires**

By Russ Chadwick, KB0TVJ, russ@wxqa.com

The APRSWXNET/CWOP data are going to all NWS Weather Forecast Offices (WFOs) in the Western Region. The data are displayed directly on the AWIPS terminals used by all of the on-line forecasters. You can see data relating to the Southern California fires here, www.met.utah.edu/droman/gacc/socc_firemap.html.

I just looked at the number of surface reports within 25 miles of each of the fires and found that APRSWXNET/CWOP is contributing about 13% of the surface data available to NWS forecasters. Here are the numbers for each of the fires where the first number is the number of APRSWXNWT stations and the second is the total number of surface stations within 25 miles of the fire location:

- Simi-incident 3/27 Piru 3/17
- Old_fire 3/26 Grand_prix 4/32
- Padua 5/37 Paradise 3/20
- Cedar 2/18

In my opinion, this has a significant impact for an all-volunteer effort. You can see more about where the APRSWXNET/CWOP stations are located at www.wxqa.com.

###

Spread Spectrum Power Control

By Darryl Smith, BE, VK2TDS, vk2tds@tapr.org

Chief Engineer, Radioactive Networks.

Introduction

When the FCC was drafting the Part 97 rules for Spread Spectrum, they felt that power control was something that should be included in operations of higher power links¹. One presumes that they felt that at lower powers the added complexity of power control was not needed given the low probability of interference.

When they were writing these rules, they could never have imagined the number of spread spectrum devices that would potentially be sharing the bandwidth just a few years later.

The purpose of this paper is to encourage the use of automatic power control in Spread Spectrum operations for all users, even those operating under Part 15.

Structure

This paper will first look at point-to-point links, analyzing a possible power control scheme for these links before expanding these ideas to point-to-multipoint links and Mesh networks.

In each case we go back to basic principles, modeling the point-to-point link, and then extending the complexity of the model.

Spread Spectrum Rules Under FCC Part 97

“(d) The transmitter power must not exceed 100 W under any circumstances.

“If more than 1 W is used, automatic transmitter control shall limit output power to that which is required for the communication. This shall be determined by the use of the ratio, measured at the receiver, of the received energy per user data bit (Eb) to the sum of the received power spectral densities of noise (NO) and co-channel interference (IO). Average transmitter power over 1 W shall be automatically adjusted to maintain an Eb/(NO+IO) ratio of no more than 23 dB at the intended receiver.”

At this point, I should make a few comments on these rules. The first is that I support the “automatic power control” requirement for all Spread Spectrum operations operating at powers above 1 W. I believe that the 100 W limit is artificial, and should not be in place, but I fully support the imposition of the 1 W limit, and would oppose raising it.

It should also be pointed out what the definition of “Spread Spectrum” is according to the FCC Part 97 rules. Under the Part 97 rules, the definition is any mode that requires significantly more bandwidth than the data rate being transferred. The common measure is a bandwidth of at least ten times the bit rate.

For 802.11b running at high speed, the bandwidth is 22 MHz, and the bit rate is 11 Mbit/s. The only reason that 802.11b must operate under the Spread

Spectrum rules is that when operating at low speeds the same 22 MHz is used for a 1 or 2 Mbit/s data rate. In addition for compatibility, when operating at the higher speeds, RTS and CTS packets are transmitted at the lowest possible speed, meaning that 802.11b operates under the Spread Spectrum rules.

Newer OFDM modes such as 802.11g operating natively would not be classed as Spread Spectrum since they are just wide band modes. What must be taken into account is that many 802.11g units also send data using Spread Spectrum for compatibility.

OFDM is the equivalent of taking a lot of 1200 bit/s modems and bolting them together to create a workable system. Thanks to software this is not too difficult.

OFDM does not achieve a gain from the method of modulation and demodulation. It achieves it's gain thanks to channel coding, allowing any errors caused by narrow band interference to be limited to a specific modem or set of modems and therefore have the data recovered.

Packet Headers Have Better BER Under 802.11b

One of the subtle additions to the 802.11b standard was that although the payload of a packet could be transmitted at any of a number of speeds, the header must be transmitted at a fixed low speed.

On the surface of it, it would appear that the

reason for this was simply to get away from a Qualcomm-type situation found in their IS-95 CDMA phones. In these phones, all packets are decoded at every possible speed with the system using the packet with the lowest number of parity errors.

But there are other advantages. Assuming that the power is fixed, data sent at a lower speed will be more likely to arrive correctly than data sent at the higher speed. That means that the header is effectively being transmitted at 11 dB higher power than payload of a packet, when operating at 11 Mbit/s.

This allows the power on a link to be tightly controlled to what is needed for a stable 11 Mbit/s signal, whilst maintaining a link margin for important protocol information, such as channel access requests

Power Control Through RTS/CTS

Right now the question that the reader should be asking is why I have brought up the subject of the packet headers so early in this paper. The reason is that many of the ideas assume that there is some way of determining the power required for a link, whilst maintaining viable communications.

The RTS/CTS exchange operates at a power level of about 11 dB higher than other packets when operating at maximum speed. This enables a higher reliability of the control signals. This 11 dB can be used as a link margin. The idea would be to use the previous power transmitted power level as a seed for setting the transmission level for

CTS/RTS packets.

Once these packets are received by their destinations, an analysis of the link margin can be performed to analyze if the power level was correct, or needs to be adjusted when the packet payloads are actually sent.

Power Requirements

There are two types of requirements for power, and enough energy must be produced from the transmitter for the particular case. They are:

- Transmission power required for error-free reception
- Transmission power required for carrier sensing

A viable implementation of 802.11b does not rely on the use of carrier detect thanks to the use of the CTS/RTS scheme to control transmission of packets.

Where a carrier detect is used, the amount of power required for error free reception is significantly greater than that required for carrier sensing. In many cases in point-to-multipoint and Mesh networks, the transmission power for most of the stations within range is that which is needed for carrier sensing.

Put another way, when receiving a signal only to detect if the channel is available, then the error rate on the received signal can be much higher.

Power Control on a Point-to-Point Link

The simplest case on power control is a point-to-point link. On a point-to-point link there are two

cases to be analyzed

- Symmetric forward and reverse path link budget
- Asymmetric forward and reverse path link budget

Symmetric Point-to-Point Link

A Symmetric point-to-point link is the simplest case of power control. Any received signal strength measurements have a direct translation to the transmit power required for the reverse path.

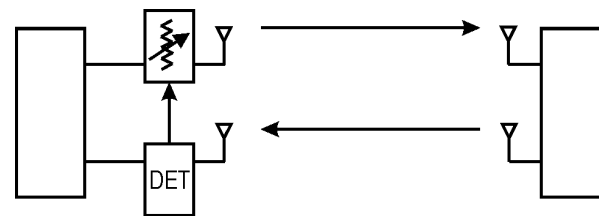

Put simply, if the received signal strength is 3 dB higher than is needed for a given bit error rate, the transmit power on the receiving station can be reduced by that by 3 dB.

Figure 1 - Single Ended Power Control

Such a scheme does cause the link to become asymmetric, with the end with the power control having a lower power output. The biggest advantage to this would be in the situation where one end of a link is on the top of a hill and it makes sense to reduce the coverage of the station.

In general, it is more useful to distribute the power reductions between both ends of a link.

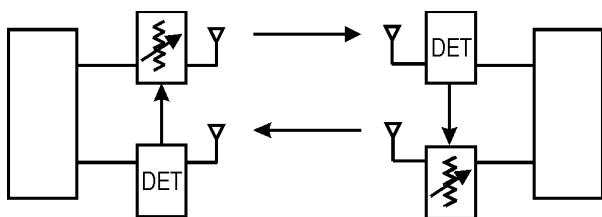
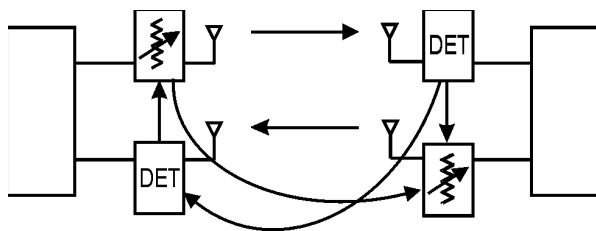

Figure 2 - Double ended Power Control - Open Loop

Simply duplicating the first scenario for both ends of the link as shown above will not work. For one reason or another, there will always be some type of imbalance and the link will become totally asymmetric, with one end being fully attenuated and the other end fully powered with the likelihood that the power distribution will oscillate over time.

Figure 3 - Double Ended Power Control - Closed Loop



One way to correct this requires some coordination between both ends of the 802.11 link to exchange information on the received signal strengths. Each end of the link would receive the signal strengths and reduce the power output by the excess receive signal. In order to maintain a stable link, some type of filtering should be used to average the received power over a number of packets.

What happens is that a feedback loop is created generating a system of closed loop power control? Some

type of dead zone is probably useful between the received power and the attenuation. How much dead zone is needed is dependant on the link.

Asymmetric Point-to-Point Link

An asymmetric point-to-point link is a symmetric link where transmit or receive amplifiers are used. A scheme of adjusting transmit power based on the receive power will not work in this situation, since it will be unstable.

There are two possible solutions to an asymmetric link

- Make the link into a symmetric link in software with an offset in the power calculations [Figure 1 - Single Ended Power Control]
- Use the symmetric link feedback scheme. [Figure 3 - Double Ended Power Control - Closed Loop]

Either of these solutions could be used.

Point-to-Multipoint Link

A point to multipoint link can be thought of as being a specific case of a large number of point-to-point links, at least superficially. There are actually a number of components to a point-to-multipoint link that need to be separately power controlled.

- Multiple hub to point connections operating at different power levels
- Broadcasts from the hub notifying other clients that they may (or may not) transmit on the frequency
- Beacons indicating the presence of a base station

In an optimal system, each of these components needs to operate on different transmit power level schemes.

Multiple Hub-to-Point Links

Where a multipoint link exists, no stations connecting

to a hub directly communicate between themselves with the possible exception for carrier sense for collision avoidance.

We can therefore consider each link between hub and each station independently for power control. That is, each station-to-hub transmission is made with the correct power for the path from that station to the hub. Each transmission from a hub directed at a station will be made with the correct power to communicate with that station.

The hub therefore needs to create a database of the power levels to use for each station when transmitting to it and to adjust the power on a per transmission basis. Depending on the power control hardware, this may not be as easy as it sounds.

Conclusion

This article is based on the first half of a paper I started writing for the 2003 DCC in Connecticut. Because of workload, I was not able to finish it for the 2003 conference, but hope to have it finished for the 2004 DCC. When finished, the paper will also explore some of novel routing techniques for wireless networks.

In this paper, I have attempted to explain how active power control might actually work in a networked environment. I have described some of the power control schemes and the issues with each of them.

1 This was actually suggested by the ARRL Future Services Committee. Later, many of those same members, including Phil Karn and TAPR, asked that the automatic power control provisions be removed.

###

Packet Status Register

#89 Autumn 2003, ISSN: 1052-3626

Published by

TAPR

8987-309 East Tanque Verde Road #337

Tucson, AZ 95749-9399 USA

phone 972-671-TAPR (8277)

fax: 972-671-8716

URL www.tapr.org

TAPR Office Hours

Monday – Thursday, 9 AM – 5 PM Central Time

Entire Contents Copyright © 2003 by TAPR. Unless otherwise indicated, explicit permission is granted to reproduce any materials appearing herein for non-commercial Amateur Radio publications providing that credit is given to both the author and TAPR, along with the TAPR phone number – 972-671-TAPR (8277). Other reproduction is prohibited without written permission from TAPR.

Opinions expressed are those of the authors and not necessarily those of TAPR, the TAPR Board of Directors, TAPR Officers, or the Editor. Acceptance of advertising does not constitute endorsement by TAPR, of the products advertised.

Postmaster: Send address changes to TAPR, P. O. Box 852754, Richardson, TX 75085-2754. *Packet Status Register* is published quarterly by TAPR, 8987-309 East Tanque Verde Road #337, Tucson, Arizona 95749-9399 USA. Membership in TAPR, which supports the electronic publication of the *Packet Status Register*, is \$20.00 per year payable in US funds.

TAPR is a community that provides leadership and resources to radio amateurs for the purpose of advancing the radio art.

Submission Guidelines

TAPR is always interested in receiving information and articles for publication. If you have an idea for an article you would like to see, or you or someone you know is doing something that would interest TAPR, please contact the editor (wallou@tapr.org) so that your work can be shared with the Amateur Radio community. If you feel uncomfortable or otherwise unable to write an article yourself, please contact the editor for assistance. Preferred format for articles is plain ASCII text (Microsoft Word is acceptable). Preferred graphic formats are PS/EPS/TIFF (diagrams, black and white photographs), or TIFF/JPEG/GIF (color photographs). Please submit graphics at a minimum of 300 DPI.

Production / Distribution:

Packet Status Register is exported as Adobe Acrobat version 5 and distributed electronically at www.tapr.org

PSR *Packet Status Register* Editor:

Stan Horzepa, WA1LOU

One Glen Avenue, Wolcott, CT 06716-1442 USA

phone 203-879-1348

e-mail wallou@tapr.org

TAPR Officers:

President: John Ackermann, N8UR, n8ur@tapr.org

Vice President: Steve Bible, N7HPR, n7hpr@tapr.org

Secretary: Stan Horzepa, WA1LOU, 2005, wallou@tapr.org

Treasurer: Jim Neely, WA5LHS, wa5lhs@tapr.org

TAPR Board of Directors:

Board Member, Call Sign, Term Expires, e-mail address

John Ackermann, N8UR, 2004, n8ur@tapr.org

Steve Bible, N7HPR, 2005, n7hpr@tapr.org

Byon Garrabrant, N6BG, 2004, n6bg@tapr.org

Stan Horzepa, WA1LOU, 2005, wallou@tapr.org

John Koster, W9DDD, 2006, w9ddd@tapr.org

Doug McKinney, KC3RL, 2004, kc3rl@tapr.org

Darryl Smith, VK2TDS, 2005, vk2tds@tapr.org

Steve Stroh, N8GNJ, 2006, n8gnj@tapr.org

Brad Noblet, WA8WDQ, 2006, wa8wdq@tapr.org

TAPR is a not-for-profit scientific research and development corporation [Section 501(c)(3) of the US tax code]. Contributions are deductible to the extent allowed by US tax laws. TAPR is chartered in the State of Arizona for the purpose of designing and developing new systems for digital radio communication in the Amateur Radio Service, and for disseminating information required, during, and obtained from such research.

TAPR MEMBERSHIP	Price	Member Price	Qty	Total	Kit Code
New		\$20.00			0
Renewal, Enter Membership Number here:		\$20.00			0
KITS					
DSP-10 2-Meter Transceiver	\$329.00	\$299.00			56
KK7P DSPx DSP Module	\$99.00	\$99.00			16
KK7P DSP10 Adapter Kit	\$39.00	\$39.00			16
PIC-E(ncoder)	\$65.00	\$58.50			16
Motorola EVM56002 Interface	\$150.00	\$135.00			16
Compact FlashCard Adapter (FlashCard not included)	\$59.00	\$49.00			16
Differential GPS (requires a GPS receiver to operate)	\$199.00	\$179.00			16
DAS (DTMF Accessory Squelch) (as seen in December 1995 QST)	\$68.00	\$61.20			8
TAPR 9600 bit/s Modem	\$80.00	\$72.00			8
Bit Regenerator (for regenerative repeater operation)	\$10.00	\$9.00			1
Clock Option (for regenerative repeater operation)	\$5.00	\$4.50			1
PK-232 Modem Disconnect (to simplify external modem connection)	\$20.00	\$18.00			2
PK-232MBX Installation Kit (for 9600-bit/s modem installation)	\$20.00	\$18.00			2
XR2211 DCD Modification	\$20.00	\$18.00			2
State Machine DCD Modification	\$20.00	\$18.00			2
State Machine DCD Modification with Internal Clock (for KPC-2)	\$25.00	\$22.50			2
FIRMWARE					
TNC2 Version 1.1.9 with KISS EPROM (includes command booklet)	\$15.00	\$13.50			4
TNC2 Version 1.1.9 command booklet	\$8.00	\$7.20			2
TNC2 WA8DED EPROM (ARES/Data standard 8-connection version)	\$12.00	\$10.80			2
TNC1 WA8DED EPROM	\$12.00	\$10.80			2
TNC2 KISS EPROM	\$12.00	\$10.80			2
TNC1 KISS EPROM	\$12.00	\$10.80			2
PK-87 WA8DED EPROM	\$12.00	\$10.80			2
TrackBox EPROM	\$15.00	\$15.00			2
MX-614 Modem IC	\$8.00	\$8.00			2
PUBLICATIONS					
Digital Communications Conference (DCC) Proceedings					
2002 DCC No. 21 (printed copy)	\$20.00	\$18.00			8
2001 DCC No. 20 (printed copy)	\$10.00	\$9.00			8
2000 DCC No. 19 (printed copy)	\$15.00	\$13.50			8
1999 DCC No. 18 (printed copy)	\$15.00	\$13.50			8
1998-2000 DCC Nos. 17-19 (CD & available printed copies)	\$50.00	\$45.00			4
1998-2000 DCC Nos. 17-19 (CD only)	\$33.00	\$30.00			4
1992-1997 DCC Nos. 11-16 (CD & available printed copies)	\$33.00	\$30.00			4
1981-1991 DCC Nos. 1-10 (CD & available printed copies)	\$33.00	\$30.00			4
Earlier DCC Proceedings (printed copies):					
Circle desired nos.: 1-4 5 6 7 8 9	\$6.00 ea.	\$5.40 ea.			8
Circle desired nos.: 10 11 12 13 14 15 16 17	\$6.00 ea.	\$5.40 ea.			8
TAPR Spread Spectrum Update	\$18.00	\$17.10			16
TAPR Software Library CD	\$20.00	\$18.00			4
Wireless Digital Communications	\$39.99	\$38.79			28
Packet Radio: What? Why? How?	\$12.00	\$10.80			8
BBS SYSOP Guide	\$9.00	\$8.10			8
Packet Status Register Vo. 1 (Nos. 1-17, 1982-85)	\$20.00	\$18.00			16
Packet Status Register Vo. 2 (Nos. 18-36, 1986-89)	\$20.00	\$18.00			16
Packet Status Register Vo. 3 (Nos. 37-52, 1990-93)	\$20.00	\$18.00			16
Packet Status Register Vo. 4 (Nos. 53-68, 1993-97)	\$35.00	\$31.50			16
OTHER					
TAPR Badge with Name and Call Sign	\$10.00	\$10.00			0
TAPR 11-oz. Coffee Mug	\$11.00	\$10.00			4
TAPR Shirt (go to www.tapr.org for details)					
GPS EQUIPMENT					
TAC-32 Software Registration	\$55.00	\$55.00			0
Garmin GPS-25 with Data Cable	\$150.00	\$135.00			28
Garmin GPS-20/25 Interface/Power Kit	\$40.00	\$36.00			8
Garmin GPS-20/25 Data Cable	\$15.00	\$15.00			2
Garmin GA-27 GPS Antenna (w/MCX conn., mag. & suction mounts)	\$75.00	\$67.50			8
Oncore UT+ GPS	\$169.00	\$149.00			28
Oncore VP Interface/Power Kit	\$40.00	\$36.00			8
Oncore GT+ GPS	\$149.00	\$129.00			28
Motorola Antenna 97 (w/BNC connector and magnetic mount)	\$65.00	\$58.50			8
MCX Right-Angle Connector with Coaxial Pigtail	\$15.00	\$15.00			2



TAPR Order Form

TAPR Business Office
P.O. Box 852754
Richardson, TX 75085-2754

Phone (972) 671-8277

Fax (972) 671-8716

Internet tapr@tapr.org
www.tapr.org

Subtotal

Sales Tax (Texas residents only, 8.25%)

Shipping

Total Order Amount

1-7 Kit Code Points: \$6.00
8-15 Kit Code Points: \$7.00
16-27 Kit Code Points: \$8.00
28-55 Kit Code Points: \$9.00
55 or more Points, contact TAPR

Name
Call Sign
Street Address
City - State - ZIP Code
Country
Phone Number
E-mail Address

Check Enclosed or Charge My Credit Card: VISA MasterCard
Account Number
Expiration Date
Signature