

PulsePuppy Installation and Operation Manual

Oscillator Carrier

Revised: 02 January 2018

© 2018 TAPR

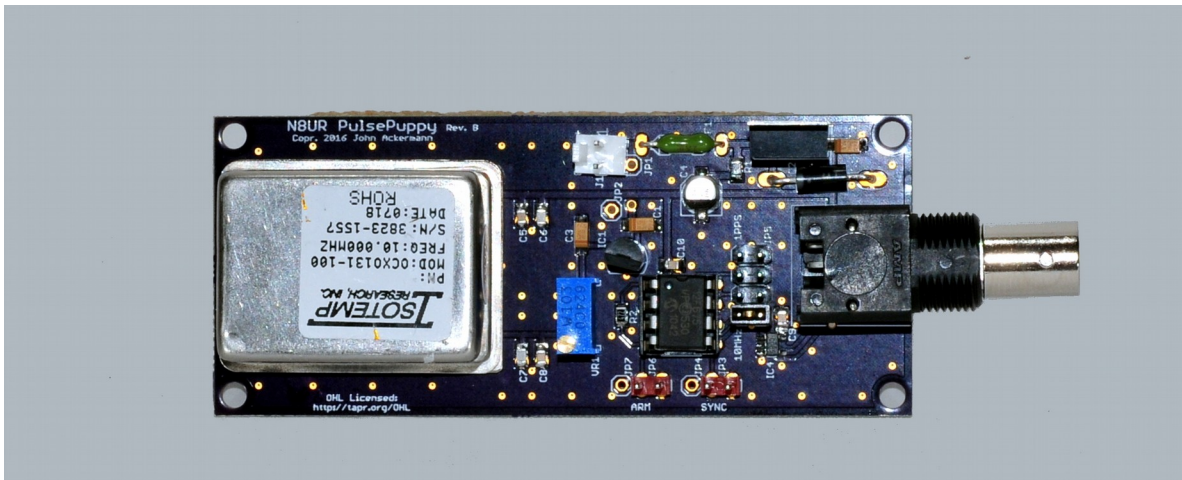

1

Introduction

The PulsePuppy is a carrier board for small user-provided oven controlled (“OCXO”) and temperature controlled (“TCXO”) oscillators. It supports “Eurocase” style OCXOs as well as a Crystek TCXO design. The default configuration is for 5 volt oscillators with square wave (usually HCMOS) outputs. The PulsePuppy output is a TTL-level square wave. An external low pass filter can be used if a sine wave output is needed.

In addition to a square-wave output at the nominal oscillator frequency, the PulsePuppy includes a frequency divider that provides outputs at 1 pulse per second (“PPS”), 10 PPS, or 100 PPS (assuming a 10 MHz source). The divider can be synchronized to an external source in the same way as the TAPR TADD-2 and T2-Mini products.

The PulsePuppy accepts from 8 to 15 VDC power input. Note that small OCXOs can have a surprisingly high power draw on start-up of 800 ma or more. This reduces quickly to a steady-state current of about 200 ma. If the power supply provides more than about 12 volts, the 7805-type voltage regulator will require substantial heat sinking and possibly replacement with another device. Lower supply voltages will keep things cool(er).

1 This photo shows the Rev. B PulsePuppy board. The Rev. C board used in production units is slightly different.

Circuit Description

The PulsePuppy schematic and board layout are included at the end of this document. The circuit consists of four main sections: (a) power supply; (b) frequency adjustment; (c) the PIC divider; and (d) the output circuit.

Power Supply

The power supply includes two voltage regulators. Diode D1 provides reverse polarity and spike suppression, while R1 and C3 provide filtering. Picofuse F1 is rated at 1.5 amp to handle oscillator startup current.

IC 1 is a 1.5 amp type 7805 regulator in a TO-220 package that provides 5 volts to the oscillator as well as the PIC chip and output buffer. As mentioned in the introduction, an OCXO can tax the 7805's capacity if the supply voltage is at the high end of the 8 to 15 volt range. Substantial heatsinking may be required, or you may consider installing a high-efficiency switching regulator such as the Murata OKI-78SR-5/1.5-W36-C (available from Digikey). The switching regulator will run cool, but may introduce additional phase noise or spurs to the oscillator output. My testing indicates that this noise is barely noticeable with a typical Eurocase OCXO.

IC 4 is a low-power 78L05 regulator feeding variable resistor VR1 to provide a frequency control voltage to the oscillator. A separate voltage regulator is used for EFC to minimize control voltage noise.

Input Circuit

Since the target oscillators have square-wave outputs, the PulsePuppy does not include the sine-to-square wave converter that is part of the TADD-2 design. However, there is provision for using a sine output device by installing a 0.1 uF capacitor at C8 instead of the normal wire jumper, and optionally installing a load resistor at R5 (value dependent on the oscillator output impedance and level). See the notes on configuration options for more details.

PIC Circuit

There's not much to say here: IC 3 is a 12F675 PIC chip, and they don't require much in the way of life support. Note that pin 4 is pulled high via a 10K resistor to Vcc because unlike the other I/O pins it does not have internal pullup or pulldown capability.

The PIC is loaded with version PD13 of Tom Van Baak's picDIV divider firmware that generates 1 pulse-per-second ("PPS"), 10 PPS, and 100 PPS outputs. The chip can be reprogrammed to provide other output rates. See Tom's page at <http://www.leapsecond.com/pic/picdiv.htm> for other picDIV options; for example, the PD14 firmware will provide equivalent output rates if you use a 5 MHz instead of 10 MHz oscillator in your PulsePuppy.

The ARM and SYNC pins allow the PulsePuppy output pulse to be synchronized to an external source such as the PPS from a GPS unit. To synchronize the PulsePuppy, ground the ARM pin for one second or more. The counter will reset and stop. Then apply a positive-going pulse to the SYNC pin. The counter will restart. The next output will occur 1 second after the leading edge of that pulse, with an accuracy of 4 clock cycles (e.g., 400 nanoseconds at 10 MHz).

The pulses produced by the PIC divider can find their way into the 10 MHz signal path. If you do not need the divided outputs, either remove the PIC chip from its socket, or permanently ground the ARM

pin (which will stop the divider). Either of these steps will ensure that the 10 MHz output is not contaminated by crosstalk from the divider.

Output Circuit

Jumper block JP1 routes either the oscillator output signal (*e.g.*, 10 MHz) or one of the PIC divider outputs (1, 10, or 100 PPS) to IC 2, a 74LVC1G08 single-gate output buffer, which drives the output connector. This buffer is an AND gate with one input wired to Vcc. Looking at the board with the oscillator at the top and connector at the bottom, the leftmost vertical pair of pins should be jumpered for direct oscillator output, the 2nd pair for 100 PPS, the 3rd pair for 10 PPS, and the right-most pair for 1 PPS. NOTE: if there is no jumper installed on JP1, the buffer gate input will float, leading to unpredictable results. Always ensure that a jumper is installed before powering up the board.

Assembly Instructions

All the surface-mount parts are pre-installed. What remains for you to add are the connectors, headers, wire jumpers, and socket. All components mount on the top of the board. Please read these instructions **AND THE CONFIGURATION OPTION INFORMATION ON THE NEXT PAGES** carefully all the way through **before** you pick up the soldering iron. Because of the tight spacing, it can be difficult to undo an assembly error. ***You have been warned!***

Ok	Procedure
	Install wire jumper at C8.
	Install wire jumper at R6.
	Install the 1.5A picofuse at F1.
	Install the SA15 TVS diode at D1. Observe proper polarity.
	Install 78L05 voltage regulator at IC4. Observe proper orientation.
	Install 8 pin DIP socket at IC3.
	Install 8 pin header.
	Install unpolarized 2-pin headers at JP2 (“SYNC”) and JP4 (“ARM”).

	Install 2 pin polarized Molex connector at J2 (DC IN) with the locking tab facing the top (oscillator end) of the board.
	Install variable resistor VR1.
	Install 7805 regulator at IC1 with the tab facing the edge of the board.
	Install the BNC connector at J1.
	For normal use, do not install R5.
	Install the programmed 12F675 chip in the socket at IC3.
	Install the oscillator at X1 or X2.

Minimalist Assembly (No EFC, No Divider)

If you only want 10 MHz output (no PPS divider) and are using the Crytek TCXO available from TAPR, which has an internal frequency adjustment control, you can build a skinny version of the board with only a few parts. Following are the steps to do that.

Ok	Procedure
	Install wire jumper at C8.
	Install wire jumper at R6.
	Install a wire in the holes for pins 7 and 8 of JP1. (This routes the oscillator signal to the output buffer.)
	Install the 1.5A picofuse at F1.
	Install the SA15 TVS diode at D1. Observe proper polarity.
	Install 2 pin polarized Molex connector at J2 (DC IN) with the locking tab facing the top (oscillator end) of the board.
	Install 7805 regulator at IC1 with the tab facing the edge of the board. You won't need a heatsink when using the Crystek TCXO as its power consumption is very low.
	Install the BNC connector at J1.
	Install the Crystek oscillator at X2.

Configuration Options

There are many inexpensive surplus oscillators available on eBay. The PulsePuppy was designed and tested with an IsoTemp model OXCO131-100 and a Crystek CH-OX20 TCXO. Both of these operate from 5 volts and have square wave (HCMOS/TTL) outputs. Building the board as described above will work for such oscillators.

There are a number of ways the board can be tweaked for other oscillators and uses. Here are some of them. **If you are using the Crystek TCXO available from TAPR, and don't need anything other than the 10 MHz output, you can do a "minimalist" build as shown above.**

NOTE: The pin assignments for these small oscillators may not be consistent from brand to brand, or model to model. Check the actual signal path before assuming that pin numbers are correct.

1. Sine wave oscillator output.

Instead of a wire jumper, install a 0.1 uF capacitor at C8. Optionally, install a load resistor at R5 (the value will depend on the output impedance and level of the source). The capacitor together with resistors R3 and R4 will cause the sine wave to be superimposed on a DC level a bit more than midway between logic switching levels. This will allow it to trigger the PIC chip or the output buffer. This simple approach does not work as well as the more complex sine-square converter in the TADD-2, but it usually works well enough. The value of R5, or if it needs to be installed, will have to be determined experimentally; the best way is to observe the junction of R3/R4/C8 with an oscilloscope.

2. 12V oscillator voltage.

If you use a 12V oscillator, do not install the jumper at R6. Instead, run a wire from the oscillator side of R6 to JP7. This will provide the input voltage (through F1) directly to the oscillator. Of course, you'll want to make sure that the 12V power supply is clean and well regulated.

3. Other oscillator voltages.

The PIC and 74LVC1G08 chips will operate from 2 volts to 5.5 volts, so IC 1 can be replaced by a regulator in that range.

4. Using internal reference voltage.

Some oscillators provide a reference output for their voltage adjustment on pin 1. In this case, do not install IC4 and instead run a wire from JP8 to IC4 pin 1.

5. Electronic Frequency Control.

The Crystek TCXO that TAPR offers does not have electronic frequency adjust (it uses a built-in trimmer), so pin 4 is normally left open. If you use a Crystek-footprint oscillator that accepts an EFC input on pin 4, run a jumper from JP9 to the adjacent X1 pin 1.

6. Additional Connections.

JP3 is in parallel with SYNC pin JP2; JP6 is in parallel with ARM pin JP4; JP5 is in parallel with DC IN at J2; and JP10 provides an extra ground pin.

7. SMA Output Connector.

You can install an SMA connector instead of the provided BNC connector. The SMA footprint is overlaid on the BNC one. If you're really clever, you might be able to mount both connectors, one on

each side of the board, but I haven't tried that.

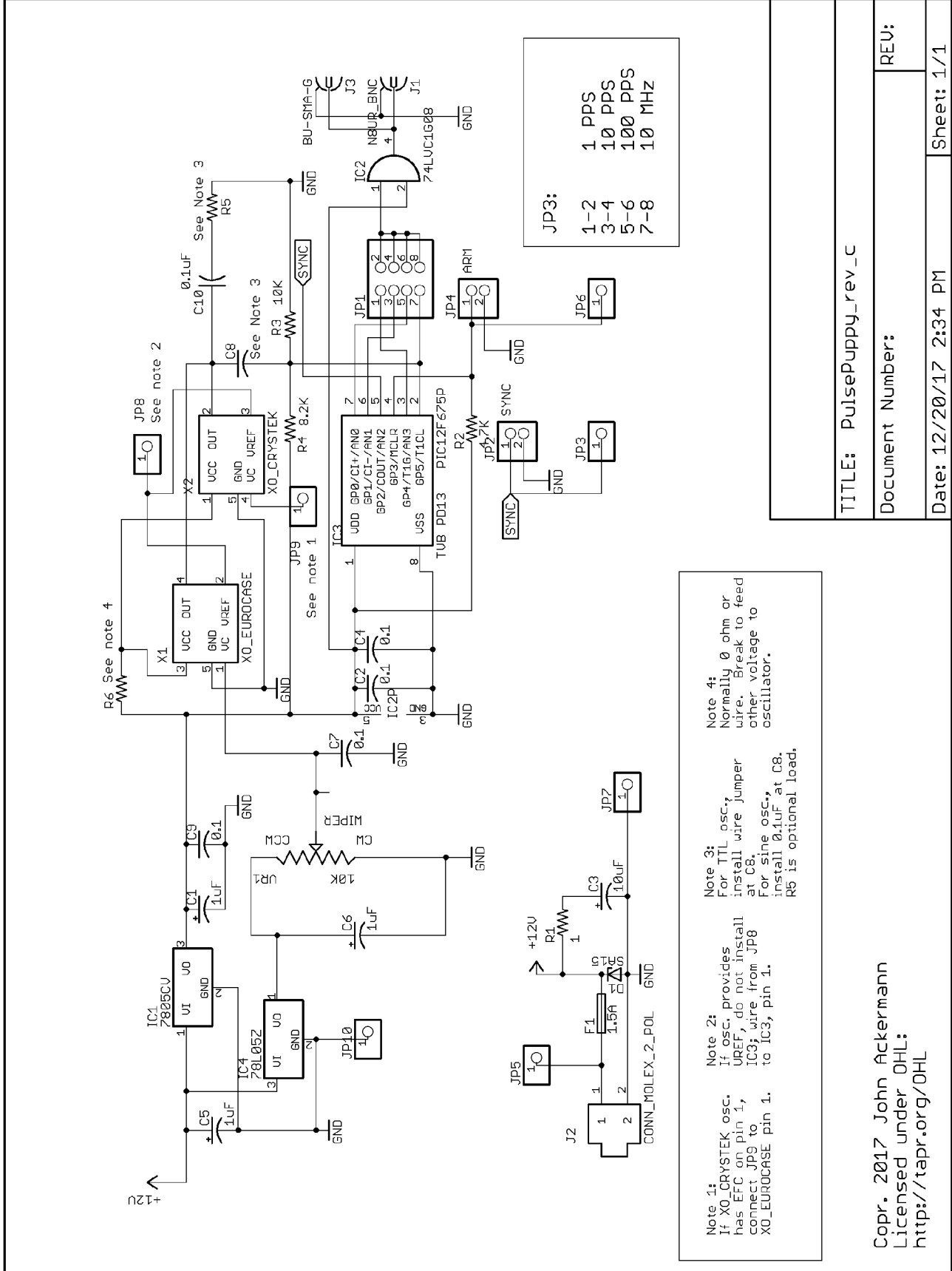

TITLE: PulsePuppy_rev_c

Document Number:

REV:

Date: 12/20/17 2:34 PM

Sheet: 1/1

Copr. 2017 John Ackermann
Licensed under OHL:
<http://tapr.org/OHL>

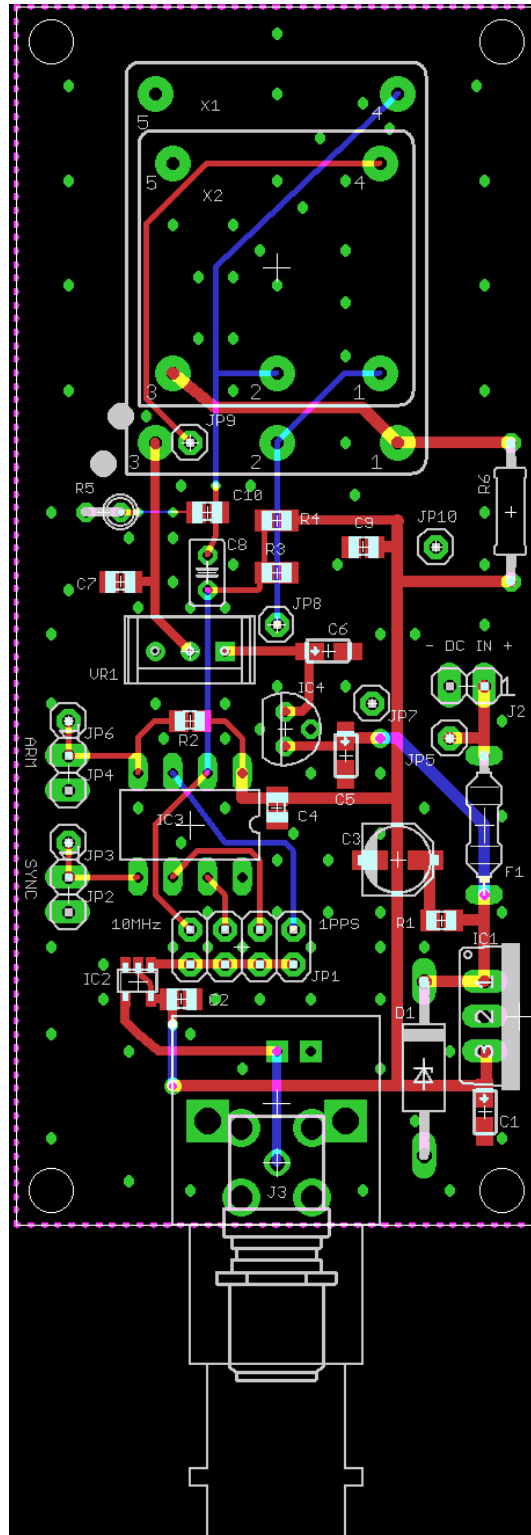

NOTE: The X1 and X2 pin numbers silkscreened on the board are in error. For X1, Eurocase, pin labels 1 and 3 are reversed. For X2, Crystek, pin labels 4 and 5 are reversed. Only the silkscreen is in error; the electrical connections are as shown on the schematic.