

TAPR / Ten-Tec Vector Network Analyzer

Instruction Manual



Issue 5

February 4, 2007

Thomas C. McDermott, N5EG

- Issue 5 of this manual applies to Version 2 of the VNA software.
- Issue 4 of this manual applies to Version 1.6 of the VNA software.

Revision History

- Issue 4 Applies to version 1.6 of the software.
- Issue 5 February 4, 2007: Applies to version 2.0 of the software, and incorporates all changes through issue 4.

Table of Contents

1. Overview.....	5
1.1. Instrument Caution	5
1.2. Temperature Limitation.....	6
1.3. Instrument Limitations.....	6
1.4. Relative Measurements.....	7
1.5. Calibration Standards	7
1.6. Hibernation or Suspension of Host Computer	8
1.7. Calibration Modes are Single-threaded	8
2. Software Installation	8
2.1. Initial Software installation	8
2.2. Supported Operating System Versions.....	9
2.3. Software Distribution	10
2.4. Installed VNA Files	10
2.5. Installation Pre-Requisites	11
2.6. Completing Installation – Connecting the VNA to your Computer	11
2.7. Uninstall.....	12
3. Detector Calibration	12
3.1. Detailed Detector Calibration Steps.....	13
3.2. Reflection Phase Detector Calibration.....	14
3.3. Reflection Amplitude Detector Calibration Short.....	15
3.4. Reflection Amplitude Detector Calibration Open	15
3.5. Transmission Phase Detector Calibration.....	15
3.6. Transmission Amplitude Detector Calibration.....	16
3.7. Coupler Directivity Calibration	16
3.8. Internal Crystal Frequency Calibration.....	16
4. Fixture Calibration.....	16
4.1. Fixture Calibration Data	17
4.2. Partial Changes to Fixture Calibration Data.....	18
4.3. Fixture Setup Diagrams	18
4.4. Actual measurement.....	19
4.5. Fixture Calibration Setups	20
4.6. Short Fixture Calibration	21
4.7. Open Fixture Calibration.....	21
4.8. 50-ohm Terminated Fixture Calibration	22
4.9. Through Fixture Calibration	23
5. VNA Software Menu	24
5.1. Shortcut Keys	26
5.2. File Menu.....	26
5.2.1. Exporting S-Parameters	27
5.3. View Menu.....	28
5.4. Calibration Menu	28
5.5. Trace Menu	29
5.5.1. Rectangular Display Mode	29
5.5.2. Polar Display Mode	30

5.5.3.	Time Domain Reflection Mode	31
5.5.4.	Choose Trace Colors.....	31
5.6.	Vertical Scale Menu.....	32
5.7.	Marker Menu	33
5.8.	Frequency Grid Menu.....	34
5.9.	Storage Menu	35
5.10.	Integration Menu	36
5.11.	Help & Software Updates.....	36
6.	Controls & Screen Display	36
6.1.	Screen Display Size & Font Adjustment	36
6.2.	'Uncalibrated' Indicator	37
6.3.	Frequency Controls	37
6.4.	Level Controls.....	37
6.5.	Apply Calibration	38
6.6.	Sweep Controls	39
6.7.	Mouse Actions	40
7.	Command Line Arguments & Multiple Test Setups	40
8.	Example Measurement.....	41
8.1	Some Cautions.....	44
8.2	Common Display Results	45
Appendix 1 – Overview of S Parameters		50
Polar Display		51
Rectangular Display		52
Group Delay		52
SWR.....		53
Appendix 2 – Calibration Details.....		55
Detector Calibration.....		55
Fixture Calibration		55
S21 Compensation.....		55
S11 Compensation.....		55
Fixture Calibration Data Set		56
Appendix 3 – Software Installation, Registry.....		57
Appendix 4 – Group Delay and Aperture		58
Aperture Shortening		58

1. Overview

This manual provides instructions for using the TAPR / Ten-Tec Vector Network Analyzer (VNA) hardware and software. Due care is required in test setup, calibration, and operational methods if the accuracy of the VNA instrument is to be fully realized. This issue of the manual applies to VNA Software Version 2.0.

If you are not already familiar with S-parameters and the concepts of forward gain and phase, reflected magnitude and phase, and polar and rectangular plots, it may be worthwhile to read **Appendix 1 – Overview of S Parameters** before continuing.

The VNA performs measurements on one-port or two-port networks. A two-port network has an input and an output (plus ground(s)). A one-port network has only an input (and ground). The input of the network is connected to the TRANSMIT (TRANSMIT) connector, and the output of the network is connected to the RECEIVE (RECEIVE) connector on the VNA.

The VNA is capable of making four measurements:

- S21 Magnitude – the gain or loss of a two-port network from the input to the output.
- S21 Phase – the transfer phase of a two-port network from the input to the output.
- S11 Magnitude – the return loss of a one-port or a two-port network referenced to the input of the network.
- S11 Phase – the phase angle of the return loss of a one-port or a two-port network referenced to the input of the network.

All the other measurements are derived from these four.

1.1. Instrument Caution

The VNA instrument places about a +3 dBm level signal (~2 milliwatts) onto the TRANSMIT connector during measurements.

Caution: Exceeding a level of +10 dBm (2 volts peak-to-peak) into either the TRANSMIT connector or the RECEIVE connector may damage the Vector Network Analyzer.

1.2. Temperature Limitation

The detectors used in the VNA are somewhat temperature sensitive. For best accuracy, always allow the unit to warm up for 10 minutes before performing any calibrations or measurements. The detector sensitivity drifts approximately 0.5 dB during warm up.

To warm up the unit, apply power to the VNA, connect the USB cable to the VNA and the host computer, then start the VNAR program on the host. The VNA remains in a partial power-down mode until the host (PC) becomes active and starts up the instrument software.

1.3. Instrument Limitations

- The dynamic range of the VNA in forward modes is limited by the noise figure of the receive pre-amplifier. It is approximately 80 dB at low frequencies, but degrades to about 75 dB at mid and high frequencies. In the reflected modes, the dynamic range is limited by the directivity of the directional coupler, which is about -35 dB at low frequencies, degrading to about -25 dB at mid and higher frequencies.
- The basic resolution of the VNA is 0.1 dB for amplitude measurements. The phase measurement resolution is 1 degree.
- The group delay measurement simply differentiates successive phase measurements. As a result, if the phase changes more than 180 degrees between successive measurement points, the group delay calculation will be wrong.
- The smallest frequency measurement interval is 1 hertz. Thus the span width (STOP Frequency – START Frequency) must be at least as great as the number of points in the frequency grid. For example, if the frequency grid is set to 1020 points, then the STOP frequency must be at least 1020 Hertz greater than the START frequency.
- The return loss of the RECEIVE circuit on the VNA is about -15 dB. This is due to variations in the pre-amplifier device. If the measurement result critically depends upon a more accurate termination, be sure to use a highly accurate attenuator of at least 10 dB between the device under test (DUT) and the RECEIVE connector. The VNA fixture calibration can do the math for you automatically (run a fixture calibration 'through' with the attenuator in place).
- The accuracy of the frequency source is determined by the on-board 12 MHz crystal oscillator, which is multiplied to 24.000 MHz before being applied to the frequency synthesizer. An external reference of 24.000000

MHz may be used if more precise frequency control is required. The VNA application *requires* that the reference frequency be 24.000 MHz, but other applications (such as a frequency generator program which is not described by this manual) can be setup to utilize different external reference frequencies. Consult the software for those other applications.

- The default frequency range on instrument startup is 200 KHz to 100 MHz. The instrument is capable of operating up to 120 MHz. However the accuracy is degraded below 1 MHz, and above 100 MHz.
- The phase detectors are accurate only down to about 20 dB above the noise floor. Thus, the phase component of an S21 measurement with more than about 60 dB attenuation is not valid. The phase component of S11 measurements is only valid to about 40 dB return loss.

1.4. Relative Measurements

The VNA does not measure absolute signal magnitude or phase delays. It takes all measurements relative to some other measurement. In most cases, this other measurement will be an instrument or fixture calibration. The accuracy of any measurement is thus directly dependent on the accuracy of the reference calibration.

Return loss measurements are extremely sensitive to the fixture configuration. Great care must be used in making S11 measurements if the data are to be reasonably accurate. For example, a single 50-ohm connector adaptor less than 1 inch in length introduces a measurable phase delay in the return loss. The VNA is capable of resolving the length of this connector adaptor when properly setup, and calibration should include all connector adaptors used in the actual measurement to the extent practical.

1.5. Calibration Standards

Some high quality commercial attenuators are not exactly 50.0 ohms in impedance. A resistance error of 0.5 ohms in the "50 ohm terminated" calibration step is enough to degrade the return loss dynamic range. Similarly, the quality of the SHORT and OPEN used in the fixture calibration can degrade the calibration. This is one reason the VNA uses SMA rather than BNC connectors for the RECEIVE and TRANSMIT ports -- these connectors cause less discontinuity than other types.

A high-quality SHORT with minimal excess inductance, and a high quality OPEN with minimal excess capacitance is needed to properly calibrate the VNA.

- A high-quality SHORT normally consists of a screw-on connector shell that shorts the center pin to the outside shell with minimal excess

inductance. These are manufactured commercially. Alternatively, an SMA receptacle with a small metal disk (with a hole drilled in the center), fit over the center pin, and soldered between the pin and the connector flange on the rear side minimizes the excess inductance and thus makes an acceptable SHORT. Either can be easily attached to an SMA cable using an SMA barrel connector.

- A high-quality OPEN consists of a connector with the projecting length of the center conductor beyond the shell insulator minimized. An open SMA connector at the end of a cable provides an adequate OPEN circuit for the calibration steps because the design of the SMA connector provides this feature. A special SMA open provides the best termination, but an open connector is adequate for many purposes.
- A high-quality 50-ohm termination is also needed for Fixture calibration.
- A 40 dB attenuator is needed when running the detector calibration routine (described in section 3); a high-quality, accurate attenuator (or a combination of 2 SMA attenuators) should be used for this purpose.
- A one-meter cable and three-meter cable are needed for detector calibration (although the exact lengths of these two cables are not critical).

1.6. Hibernation or Suspension of Host Computer

The VNA instrument can not automatically recover from the host computer hibernating or suspending. If the host computer (typically a laptop) hibernates or suspends, you will have to remove power from the VNA and exit the VNA software. Then reconnect power to the VNA and restart the VNA application.

1.7. Calibration Modes are Single-threaded

The VNA software is multi-threaded. This means that other Windows programs can run while the VNA is acquiring data in the background. However both fixture and instrument calibration are single-threaded code. This means that these two calibrations routines will stall if another Windows program has the *focus*, and will continue when the VNA application regains focus. The progressbar may take awhile to update after the VNA program regains focus.

2. Software Installation

2.1. Initial Software installation

The VNA software is installed from the included CD-ROM. Additionally, you may need to install the Microsoft Windows® dotNET 2.0 run-time (and even possibly the Windows installer). All the programs are located on the included CD-ROM.

Note: Remove the USB cable and disconnect the VNA prior to inserting the CD-ROM and starting the software installation.

- You must have *administrator* privileges (if using windows NT, 2000, or XP). Insert the CD-ROM into your CD drive. The installer should start automatically. If it does not, using Windows Explorer open the icon that the CD is inserted into, and double-click the 'setup.exe' file.
- Select the directory for installation. The default directory is:
C:\Program Files\TAPR\VNA.
- If the installer gives a notification that the dotNET 2.0 runtime is not found, you have two choices:
 - Recommended: Install the most recent dotNET 2.0 framework via the Internet from the Microsoft website. This will be approximately 23 MB in size, and is referred to as the redistributable for x86 processor (Intel/AMD processors are x86 architecture). It will be named 'dotnetfx.exe'. This will assure that you get the most current version with recent service patches. The URL at the time this manual was written is:

<http://msdn2.microsoft.com/en-us/netframework/aa731542.aspx>

- **At this time, the supplied CDROM contains the .NET 1.1 runtime, and version 1.x of the VNA software.**
- **Version 2 of the software needs to be downloaded from the TAPR website at**

http://www.tapr.org/software_library.php?dir=/pub/n5eg

- **The current status of the VNA software is maintained in the file 'current.htm' located at the above URL.**

2.2. Supported Operating System Versions.

The Vector network analyzer software should be able to run on the Windows operating systems as shown:

Operating System	Support	Reason(s)
Windows 95 – all editions	No	Does not support USB. Does not support .NET framework Does not support current Windows Installer
Windows 98 – Gold	Maybe	Does not support USB version 1.1, only supports USB version 1.0
Windows 98 – SE (Second Edition)	Yes	Tested.
Windows ME	Probably	Not tested yet.
Windows NT	Probably	Not tested yet
Windows 2000	Yes	Tested.
Windows XP	Yes	Tested.
Windows Vista	Maybe	Not tested.

2.3. Software Distribution

You must be logged on with *administrator* privileges if using Windows NT, 2000, or XP in order to install the software.

Version 2 of the software distribution consists of the following files:

Filename	Function
Setup.exe	Installer bootstrap. Detects if suitable Windows installer is present, provides web assistance if not.
Setup1.msi	The VNAR3 application (including supporting files) in windows installer format.

2.4. Installed VNA Files

The VNA software installer loads the following files, by default in C:\Program Files\TAPR\VNA\. The file location can be changed during installation.

File name	Where installed	Function
VNAR3.exe	Default directory.	Host program.
VNAR3 Help.chm	Default directory. Needs to be in same directory as VNAR3.exe	Compiled help file.
VNA_target.bin	Default directory. Needs to be in same directory as VNAR3.exe	Binary image of target AN2135 software. Downloaded to target by the host program

File name	Where installed	Function
ezusb.sys	Win98, ME: C:\WINDOWS\SYSTEM WinNT, Win2000, WinXP: C:\WINDOWS\SYSTEM32\DRIVERS	Device driver for AN2135 USB target.
ezusbw2k.inf	For all Windows versions: C:\WINDOWS\inf	Information file used to associate USB device with ezusb.sys driver.
gpl.txt	Default directory.	License terms for VNA software.

2.5. Installation Pre-Requisites

- **Version 2.x (newer versions) of the software**

The 2.x versions of the VNA software require that the host have a reasonably current Windows installer program, and that it have the Microsoft .NET 2.0 framework run time package installed. The installer will check for these prior to installing. Version 2 of the dotNET Framework redistributable can be found on the Microsoft website, it's about 22 MB in size, and is called *dotnetfx.exe* at the time this was written (same name as the older framework). Don't delete the .NET 1.1 framework, since many other applications still need it, and the two versions can run side-by-side.

- **Version 1.x (older versions) of the software**

The 1.x versions of the software require that the host have a reasonably current Windows installer program, and that it have the .NET 1.1 framework run time package installed (version 1.0 is not sufficient). The installer will check for these prior to installing. The installer will attempt to link to the Microsoft web site providing a download menu if the pre-requisite is missing. Microsoft has many different programs on this web page; you need the one that is approximately 23 MB in size, and is called the "*redistributable*" (it is allowed to be redistributed by applications). Download and install as needed, the filename is dotnetfx.exe. The .NET framework redistributable is included on the CD-ROM, but we recommend downloading the latest version from Microsoft (its about 23 MB in size). Many newer applications and some recent Microsoft service packs install the framework, so you may have it already.

2.6. Completing Installation – Connecting the VNA to your Computer

After installation of the software using the setup program is completed, connect the VNA to your computer using a USB cable. Then plug the supplied +5V power cube into a proper outlet and connect the 2.1mm plug into the power receptacle on the VNA. This sequence will activate Windows “New Hardware Detected Wizard”. The wizard will find the VNA device and attempt to find an associated device driver. When prompted, let the wizard search to find the driver (since it should have been installed there by the setup program).

2.7. Uninstall

The installer program will create an uninstall module. If you need to uninstall the VNA application, use the control panel -> add new software selection, and use it to uninstall the application. The uninstaller will not delete the Registry key or ezusbw2k.PNF files. You may delete these manually if you wish, but it's not required. See Appendix 3 for details.

3. Detector Calibration

There are two different types of calibration: Detector (instrument) calibration, and Fixture calibration. They serve different purposes and both types of calibration are necessary. Section 4 describes Fixture calibration, this section describes Detector calibration.

The magnitude detectors on the VNA produce an output voltage that varies as the input signal magnitude to the detector is changed. The detector calibration routine measures these voltages across a range of different amplitudes that are sent to both the transmission and reflection detectors. The detector calibration software models the detector voltage response function, and saves these data sets in the file 'detector.ica'.

Similarly, the phase detectors produce an output voltage proportional to the phase difference between the input and the internal frequency synthesizer. The detector calibration routine measures the output voltages across a range of phase differences for both the transmission and reflection phase detectors. The resultant tables are saved along with the previous magnitude data sets in this same 'detector.ica' file.

When the VNA is started, it searches for the file 'detector.ica' in the startup directory. If this file is not present, then there will be no detector calibration information available. The VNA will attempt to use default values for the detector constants, but the accuracy will be *very poor*. The VNA software will warn you that it has not found the detector calibration file.

Detector calibration normally only needs to be run once, the first time the VNA used. Before starting the calibration, make sure you have a one meter 50 ohm

cable, a three meter 50 ohm cable, a 40dB attenuator (or equivalent attenuation, for example a 10 dB plus a 30 dB SMA attenuator in series), and a high-quality "SHORT" (as described in section 2) available. The cable lengths need not be exact. Ten-Tec provides 3 cables, 2 SMA barrel connectors, and a SMA 50 ohm load.

After letting the VNA warm up for at least ten minutes, run the "Detector Calibration" command from the Calibration menu; as detailed in Section 3.1 of this manual. Run the calibration steps in sequence, and according to the instructions provided in the calibration dialog box. After you have finished all the calibration steps, click the SAVE button. This will compute the corrections necessary to compensate for hardware variations, and save the file 'detector.ica' in the startup directory.

Normally, the detector calibration needs to be run only one time, but future software updates may require re-running the detector calibration. Each calibration file is version-marked so that if the format changes in future software revision, that software can detect the version and validate or reject the existing calibration data set.

Once the detector calibration file is present, the VNA software will no longer issue a warning at startup.

The Detector Calibration dialog box lists the 4 individual steps needed to perform the calibration. After each step is completed, and green check mark will appear next to that step. Follow the steps in order, and connect the cables, SHORTS, and 40 dB ATTENUATOR as described by each step prior to starting that step. After all the steps have been completed and each has a check mark present, click the 'SAVE' button.

Note: the Instrument Calibration routine implements only very rudimentary error detection on TRANS and REFL amplitude calibrations. Previously, the routine would blindly accept any results even if they were grossly wrong. The error detection cannot detect all (or even some common) error cases, so make sure you properly setup the cables for the Detector Calibration, and that the cables make good electrical contact.

3.1. Detailed Detector Calibration Steps

Refer to the figures in this section for cable and load connections for running the detector calibration sequences. These are the steps outlined in the program Detector Calibration Menu.

The progress bar on the display will indicate the progress of each individual calibration step. Some of the steps can take 3-4 minutes to complete.

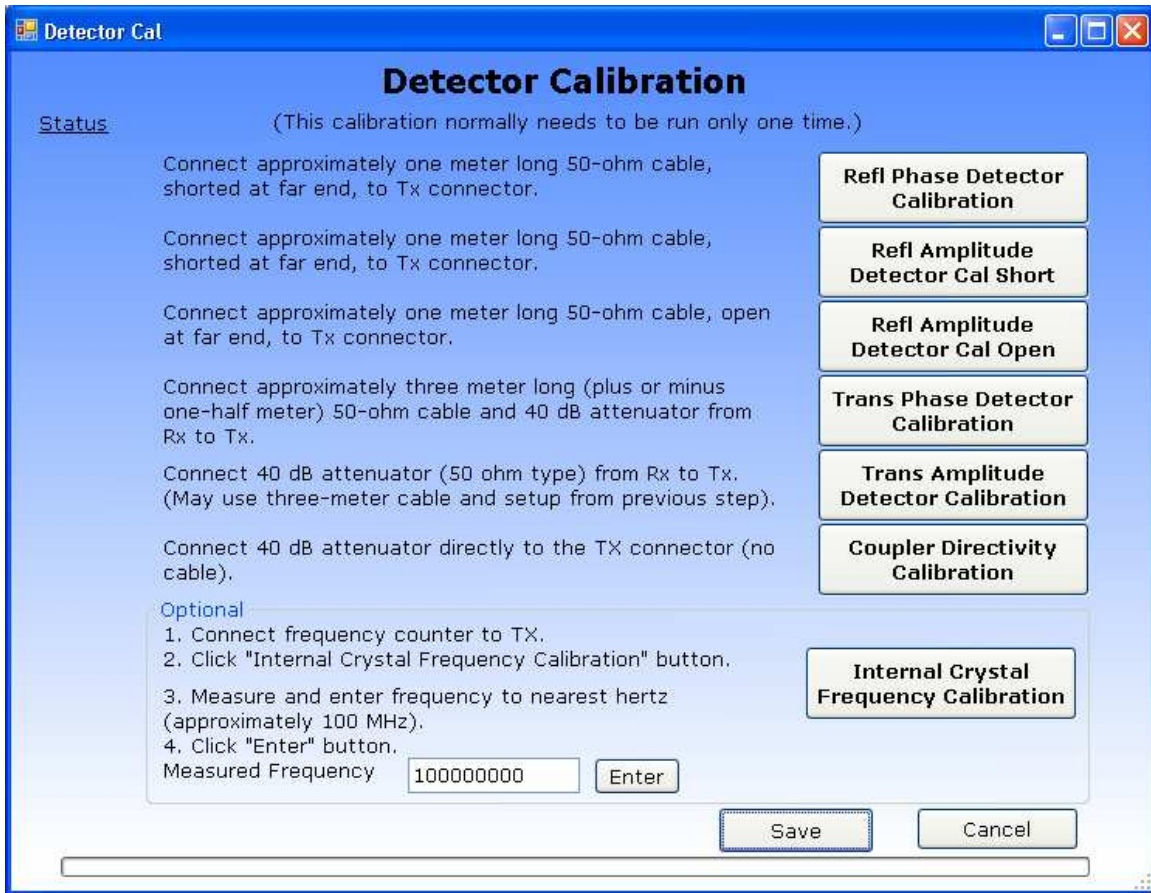

Figure 3.1 – Detector Calibration Menu

3.2. Reflection Phase Detector Calibration

To calibrate the reflection phase detector, connect the 1-meter long cable to the TRANSMIT connector of the VNA. The far end of the cable must be connected to the SHORT (through a barrel if necessary). Then click the 'Refl Phase Detector Calibration' button. See figure 3.2.

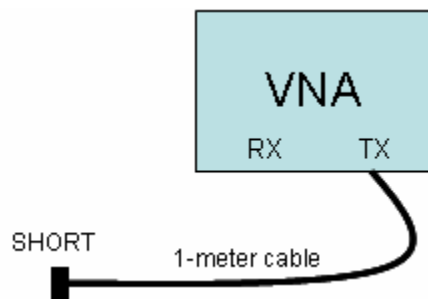

Figure 3.2 – Refl Phase Detector Calibration and Refl Amplitude Detector Calibration.

3.3. Reflection Amplitude Detector Calibration Short

To calibrate the Reflection Amplitude Detector Short, connect the 1-meter long cable to the TRANSMIT connector of the VNA. The far end of the cable must be connected to the SHORT (through a barrel if necessary). Then click the 'Refl Amplitude Detector Calibration Short' button. See figure 3.2. This step runs slowly, and may take several minutes to complete.

3.4. Reflection Amplitude Detector Calibration Open

To calibrate the Reflection Amplitude Detector Open, connect the 1-meter long cable to the TRANSMIT connector of the VNA. The far end of the cable must be OPEN. Then click the 'Refl Amplitude Detector Calibration Open' button.

3.5. Transmission Phase Detector Calibration

To calibrate the Transmission Phase Detector, connect the 3-meter cable to the TRANSMIT connector of the VNA, connect a 40 dB attenuator (or a 10 dB plus a 30 dB attenuator in series) to the end of that cable, then connect the other end of the attenuator to the RECEIVE connector on the VNA. Then click the 'Trans Phase Detector Calibration' button. See figure 3.3.

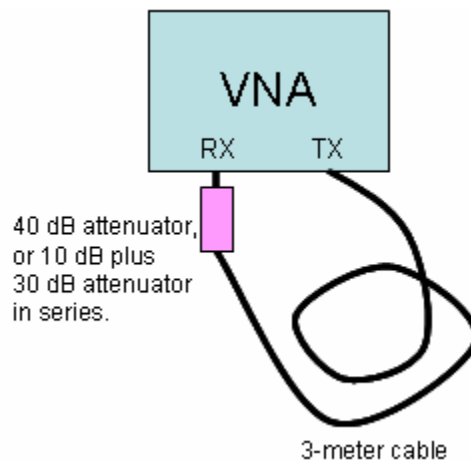

Figure 3.3 – Trans Phase Detector Calibration, and Trans Amplitude Detector Calibration

3.6. Transmission Amplitude Detector Calibration

To calibrate the Transmission Amplitude Detector, leave the connection of the previous step 3.3 (Trans Phase Detector) in place, and click the 'Trans Amplitude Detector Calibration' button.

3.7. Coupler Directivity Calibration

To calibrate the Coupler Directivity, connect a 40 dB attenuator (or 10 dB and 30 dB attenuators in series) directly to the TX connector without any intervening cables.

3.8. Internal Crystal Frequency Calibration

Optionally, the internal crystal oscillator may be calibrated. To do so, connect a frequency counter capable of operating at 100 MHz to the TRANSMIT connector, then click the 'Internal Crystal Frequency Calibration' button. Enter the reading displayed on the frequency counter in the text box to the nearest hertz. The value must lie in the range 97000000 to 103000000 (97 MHz to 103 MHz) or it will be rejected. Click the 'Enter' button to accept the entered value. The crystal error will be computed, and used to improve the frequency accuracy. The internal crystal oscillator drifts tens of PPM with temperature changes, so you may wish to re-calibrate the frequency at any time. After entering a measured value, the 'Internal Crystal Frequency Calibration' button can be clicked again to check the value.

It is not necessary to re-run the other detector calibration steps if you just want to re-run the frequency calibration. The previously saved values will be retained.

When all detector calibration steps have been completed, click the 'Save' button.

4. Fixture Calibration

Each specific test fixture (test setup) consists of connectors, cables, adaptors, and other things that affect the S21 and S11 measurements. Each test fixture setup has different physical properties. For example, the length of each interconnecting test cable affects the phase of all measurements (due to the propagation time delay specific to that particular cable). Therefore, each test setup requires a different set of calibration data to compensate for not only the test setup, but also propagation delay and other errors in the VNA device itself. The VNA software can perform these "fixture calibrations", you can take and save one for each different measurement set up that you use. Each calibration

can be saved with a different file name. Use as descriptive a filename as possible so that you can remember exactly what each fixture calibration refers to!

Before the Fixture calibration is started, have a 'SHORT', 'OPEN', '50-ohm TERMINATION', and a Connector Bullet (or barrel) available. As discussed previously, OPEN is just the open end of an SMA cable with nothing connected.

4.1. Fixture Calibration Data

A fixture calibration data set is built from four raw data measurements – 'Open', 'Short', 'Terminated', and 'Through'.

Typically, the following procedure is used to make a calibration data run:

- 1) The cable from the VNA TRANSMIT connector to the device under test (DUT) is disconnected *at the DUT*, and is terminated sequentially in a series of precision loads:
 1. The 'Short' calibration is conducted with the zero-ohm load at the end of the TRANSMIT cable.
 2. The 'Open' calibration is conducted with the infinite-ohm load at the end of the TRANSMIT cable.
 3. The 'Terminated' calibration is conducted with the 50-ohm load at the end of the TRANSMIT cable.
- 2) Then the "Through" calibration is performed after putting a connector barrel or bullet (usually a double-female connector adaptor) in place of the DUT.
- 3) The error compensation parameters are computed, and the data set is saved with a descriptive filename using the extension '.cal'.

The Fixture Calibration dialog box lists the 4 individual steps needed to perform the calibration. After each step is completed, and green check mark will appear next to that step. Follow the steps in order, and connect the SHORT, OPEN, TERMINATION, and THROUGH fixture setup as described by each step prior to starting that step. After all the steps have been completed and each has a check mark present, click the 'SAVE' button.

Both interconnecting cables are left in place because they are part of the measurement error; the calibration removes both the time delay and any amplitude change they and the connectors cause.

The calibration routine makes 1024 measurements, starting at 200 KHz, and stopping at 120 MHz; it linearly spaces the frequency samples about 117 KHz apart. It is assumed that the test fixture itself (without the DUT) does not contain any high-Q resonances. If it does, large uncertainty will be introduced into the measurements (whether or not calibrated). The DUT of course can have high-Q resonances, just not the fixturing or interconnecting cables. When applying calibration, the software linearly interpolates between the two calibration

frequencies closest to the actual measurement frequency, and uses that to compensate the measurement.

If the "Open," "Short," or "50-ohm" loads are not accurate, then the compensation will be wrong. At 100 MHz, the VNA is fairly sensitive to the accuracy of these loads.

Normally, there will be a number of different calibration data sets taken and stored, one for each test setup. These can have any valid windows filename (so it's helpful to be descriptive and verbose with the filename), but the extension is always '.cal'. The "Apply Fixture Calibration" checkbox is grayed-out until a valid Fixture Calibration Data set is loaded.

4.2. Partial Changes to Fixture Calibration Data

It's possible to partially update the Fixture calibration data. For example, assume that the cable from the DUT to the VNA RECEIVE connector is changed. This does not affect the S11 measurement, but will change the S21 measurement. In this case, a previously saved calibration dataset can be loaded, and just the one measurement ('Through') run, then the dataset saved with a new name or with the existing name as appropriate. The newly saved data set will inherit the S11 raw and derived errors from the older dataset, but will use the new 'through' measurements. In fact, this can be done with any or all of the four measurements.

4.3. Fixture Setup Diagrams

The following three diagrams show how the fixture needs to be setup during the fixture calibration process, and during the actual measurement using the fixture. The following dialog box shows the four steps needed for fixture calibration. The diagrams in this section show the connection required to perform the individual calibration steps.

4.4. Actual measurement

The cables, connectors, and adaptors connecting both the TRANSMIT and the RECEIVE connectors to the DUT are part of the test fixture. These exact same cables connectors, and adaptors must be left in place during the Fixture calibration steps, while the DUT itself is removed and replaced with various loads and connector barrels during the Fixture Calibration steps.

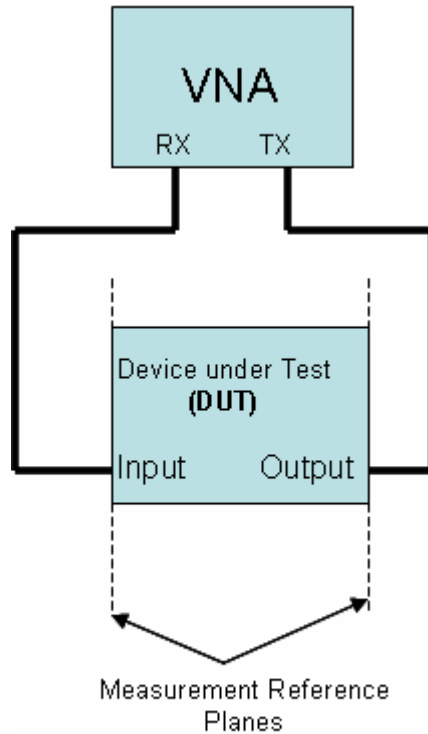

4.5. Fixture Calibration Setups

Only the cables, connectors, and adaptors connecting the TRANSMIT to the calibration loads are part of the text fixture during the first three fixture calibration steps. The fourth step also uses the cables, connectors, and adaptors in the RECEIVE connection as well in order to complete the fixture calibration. Typically all the cables, connectors, and adaptors are left in place, and only the DUT is removed during the Fixture Calibration steps.

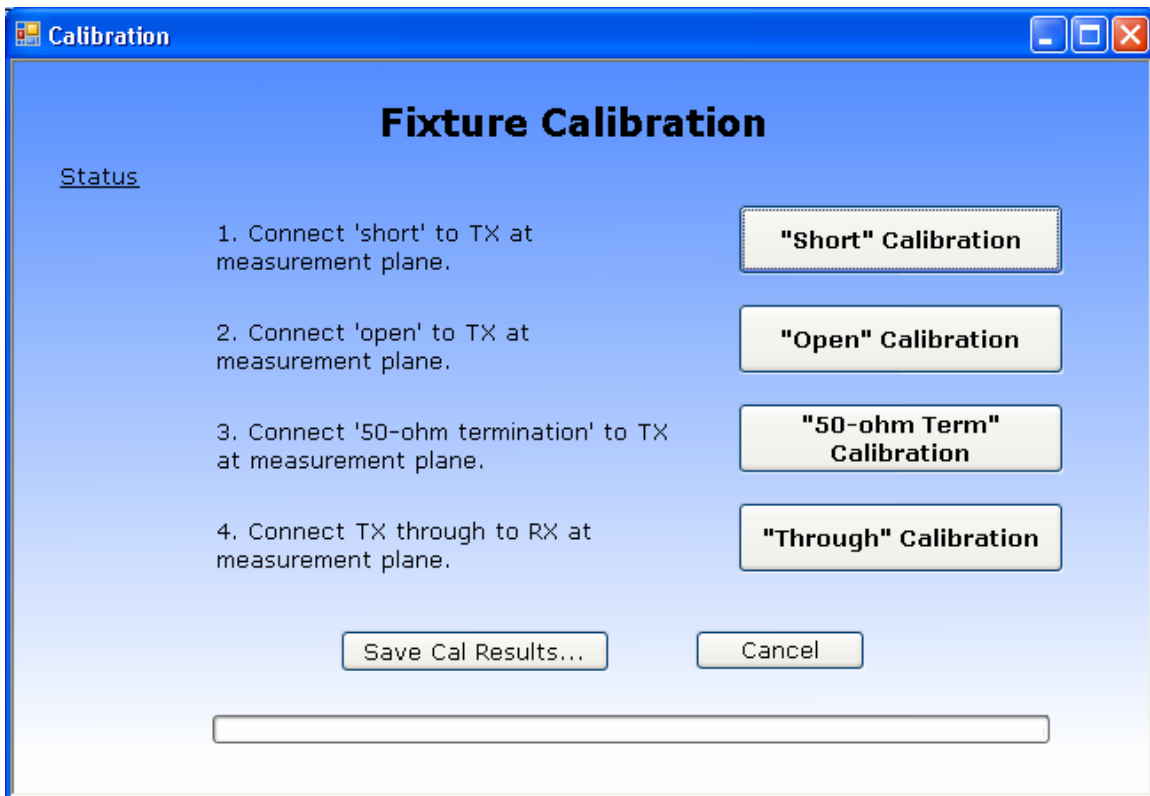
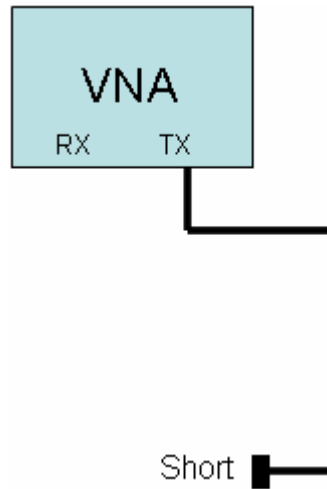

Figure 4.5 – Fixture Calibration Menu

Once all four steps are completed, click the “Save Cal Results...” button. This will allow you to choose a file name and location. Be sure to use a description filename, as you are likely to have many different fixture calibration files. Filenames are allowed to be long and may contain embedded spaces. The software will automatically append a .cal suffix to your name. Filenames are not limited to an 8.3 format, which would not be sufficiently descriptive.

4.6. Short Fixture Calibration



4.7. Open Fixture Calibration

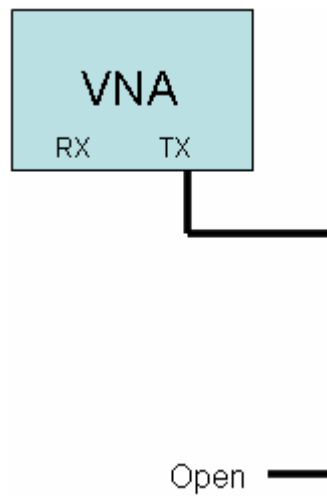

4.8. 50-ohm Terminated Fixture Calibration

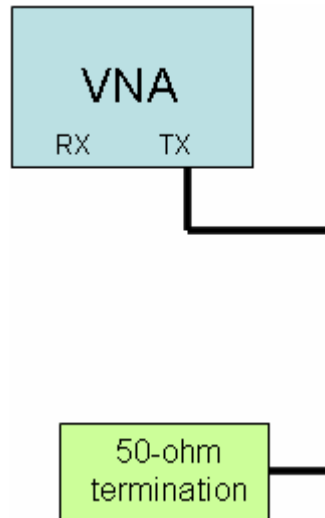

4.9. Through Fixture Calibration

The cables, connectors, and adaptors connecting both the TRANSMIT and the RECEIVE connectors to the DUT are part of the test fixture. Additionally, the bullet connector is part of the calibration test fixture even though it will not be present in the actual measurement. This represents a source of uncompensated error. Thus the connector bullet must be short, low loss and impedance-matched to the cables in order to minimize these errors.

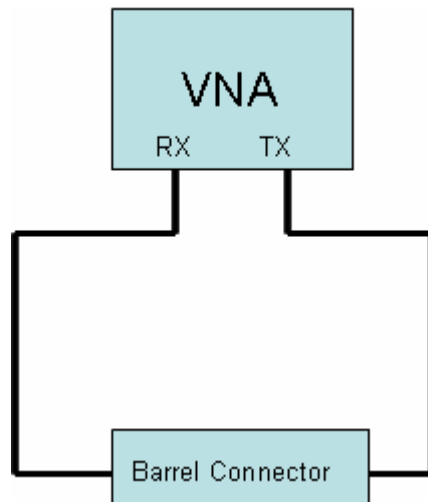

5. VNA Software Menu

The following menu items are available in the VNA program. Each menu item is explained in the following sections.

File

- Print
- Print Setup
- Print Preview
- Set Plot title
- Store Forward Parameters
- Store Reverse Parameters
- Export S-parameters
 - Rectangular Format
 - Polar Format
 - CSV Rectangular Format
- Save Configuration + Measurements ...
- Load Configuration + Measurements ...
- Exit

View

- Rectangular
- Polar
- Time Domain Reflection

Calibration

- Detector Calibration
- Run Fixture Calibration
- Load Fixture Calibration File

Trace

- S11 Magnitude (rectangular)
- S11 Phase (rectangular)
- S21 Magnitude (rectangular)
- S21 Phase (rectangular)
- S21 Group Delay (rectangular)
- S11 Magnitude as SWR (rectangular)
- Raw Calibration Data S21 – Through (rectangular)
- Et – Tracking Error
- Es – Source Mismatch Error
- Ed – Directivity Error
- Raw Calibration Data S11 – Short
- Raw Calibration Data S11 – Open
- Raw Calibration Data S11 – Terminated
- Choose Trace Colors
 - S11 Magnitude Color
 - S11 Phase Color
 - S21 Magnitude Color
 - S21 Phase Color
 - S21 Group Delay Color

SWR Color

Vertical Scale

- 10 dB / division
- 5 dB / division
- 2 dB / division
- 1 dB / division
- SWR 1.0 to 11.0
- SWR 1.0 to 6.0
- SWR 1.0 to 3.0
- SWR 1.0 to 2.0
- 10 microseconds / division
- 1 microsecond / division
- 100 nanoseconds / division
- 10 nanoseconds / division
- 1 nanosecond / division
- 100 picoseconds / division
- Group Delay Aperture = 1
- Group Delay Aperture = 4
- Group Delay Aperture = 16
- Group Delay Aperture = 64

Right Scale display

- Phase
- SWR
- Delay

Polar Zoom

- Zoom = 1.0
- Zoom = 1.5
- Zoom = 2.0
- Zoom = 2.5

TDR Setup

Marker

- Change Marker Frequencies
- Clear All Markers
- Marker Numbers
 - Enable
 - Disable
- Marker Parameters
 - Enable
 - Disable

FreqGrid

- 100 points
- 200 points
- 400 points
- 1020 points

Storage

- Store
- Recall
- Display Storage

Help

Display Help

About

Launch Browser (to check for Software Updates)

5.1. Shortcut Keys

Shortcut keys have been assigned to a few of the common menu items. Typing the shortcut on the keyboard has the same effect as clicking the menu item with the mouse. The shortcuts are listed alongside each menu item so they can be easily found without reference to this manual. Here's a list of the shortcuts:

Shortcut Key	Function
Alt + R	Rectangular Display Mode
Alt + P	Polar Display Mode
Alt + T	TDR Display Mode
Alt + E	Exit the VNA application
Ctrl + P	Print
Ctrl + S	Save the configuration and measurement data to a file
Ctrl + L	Load a configuration and measurement data set from a file
Ctrl + C	Run a Fixture Calibration
Ctrl + M	Clear all Markers
Ctrl + D	Toggle Storage Display on/off
Ctrl + 1	Set 1x Integration Mode
Ctrl + 2	Set 2x Integration Mode
Ctrl + 4	Set 4x Integration Mode
Ctrl + 8	Set 8x Integration Mode
Ctrl + 6	Set 16x Integration Mode
F1	Display Help
F2	Toggle S11 Magnitude trace on/off
F3	Toggle S11 Phase trace on/off
F4	Toggle S21 Magnitude trace on/off
F5	Toggle S21 Phase trace on/off
F6	Toggle S21 Group Delay trace on/off
F7	Toggle SWR trace on/off

5.2. File Menu

The File menu allows printing the measurements in graphical format, and storing the S-parameters in a text file.

Print – prints the selected view (rectangular or polar) to the printer.

Print Preview – provides a preview of what the printed page will look like

Print Setup – allows selecting the desired printer and setting the print parameters

Set Plot Title – allows setting / clearing a textual title for the plot that appears underneath the scope display

Store Forward Parameters – store the measured reflection and transmission data as S11 and S21 to temporary storage

Store Reverse Parameters – store the measured reflection and transmission data as S22 and S12 to temporary storage

Export S-Parameters – exports the stored data in text format

Rectangular Format – Real and Imaginary components of the S-parameters normalized to 50 ohms.

Polar Format – Magnitude, in dB, and Phase in degrees of the S-parameters normalized to 50 ohms.

CSV Rectangular Format – Real and Imaginary components of the S-parameters normalized to 50 ohms to a Comma-Separated-Variable (CSV) file that can be read by Microsoft Excel.

Save Configuration + Measurement – Saves the complete state of the instrument settings and display traces to a file (except stored S-parameters). The filename can be selected and should be very descriptive.

Load Configuration + Measurement – Loads a previously saved configuration file to restore the state of the instrument from a previous measurement setup.

Exit – immediately terminates the VNA application (and saves the current instrument configuration to the file: __last.cfg).

5.2.1. Exporting S-Parameters

The VNA is a reflection-transmission test set. It can only measure half of an S-parameter data set (S11 and S21 in the forward direction) at one time. The DUT must be physically reversed in the test setup in order to measure the other direction (S12 and S22 in the reverse direction).

To measure and export a complete 4 parameter set:

- First set the frequency sweep (start and stop frequencies), and apply calibration as desired.
- Make a measurement sweep in the forward direction
- Store Forward Parameters.
- Next, physically reverse the DUT (exchange input and output).
- Make a measurement sweep in the reverse direction without changing the frequency sweep or calibration-applied boxes.
- Store Reverse Parameters
- After these two datasets have been stored, you may Export the S-Parameters in either the Rectangular or Polar formats to a text file.

Both the forward and reverse storage arrays are locked once stored; this prevents accidental over-write. The menu items appear with a checkmark when locked. The only way to unlock them is to Export the file. Both forward and reverse arrays must be filled before the Export function can work.

Note that the CSV save format embeds COMPLEX functions into the output Excel spreadsheet. Excel must have the analysis toolpack installed to use complex functions. If you see the value #NAME in the cells when using Microsoft Excel, you will need to load the toolpack into Excel, normally found using the Tools->Addins menu within Excel.

5.3. View Menu

The View menu allows selecting the display view:

- 1) Rectangular
- 2) Polar
- 3) Time Domain Reflection

The Rectangular display can display S11 magnitude and phase, and S21 magnitude, phase, and group delay. It can also show S21 ('Through') calibration parameters. Magnitude is plotted as dB vs. frequency, phase is plotted as degrees vs. frequency, and group delay is plotted as time vs. frequency. The display units (dB/div, and seconds/div) can be selected in the VertScale menu.

The Polar display can display S11 (reflection measurement) and the calibration data associated with reflections measurements. The Polar display does not show S21 measurements.

The Time Domain Reflection (TDR) mode performs a reflection measurement then converts from a frequency measurement into the real part of the time domain response. It displays the TDR response versus time. It is useful for testing cables for faults. The TDR markers will calculate the distance from the reference plane to the point indicated by the marker. The TDR resolution is 4.1 nanoseconds. This limits the resolution of the cable fault to about 1.3 feet (or about 0.4 meters). The TDR mode ignores the Start and Stop frequencies, it needs to setup a custom grid.

5.4. Calibration Menu

The Calibration menu provides three options:

- 1) Generate (and save) a Detector calibration data set.

The detector calibration data set is auto-loaded by the application if it exists. It does not normally need to run except the first time the instrument is used. Only one detector calibration file is needed.

- 2) Run (Generate, load, and save) a fixture calibration data set.
A separate fixture calibration set is needed for each different test fixture.
- 3) Load a previously saved test fixture calibration data set by name.

The Detector calibration procedure is described in section 3.

The Fixture calibration procedure is described in section 4.

Appendix 2 – Calibration Details provides a more detailed description of how the calibration routines work.

5.5. Trace Menu

The Trace menu allows selecting which measurements are displayed. The Polar display only displays reflection measurements (S11) and related raw and derived calibration constants. The rectangular display can show both S11 and S21 measurements, and the calibration constants related to S21.

Device Under Test – DUT

The reflection and forward measurements are made with respect to the Device Under Test (DUT). The reference plane location is established when the fixture calibration is run and loaded.

5.5.1. Rectangular Display Mode

S21 can be displayed only on the rectangular display. S11 can be displayed on both the rectangular and polar displays. The traces that can be displayed on the Rectangular display are:

S11 Magnitude	The magnitude, in dB., of the input return loss of the Device Under Test (DUT).
S11 Phase	The phase angle, in degrees, of the input return loss of the DUT, from +180 to –180.
S21 Magnitude	The magnitude, in dB. of the forward transfer gain (or loss) of the DUT.
S21 Phase	The phase, in degrees, of the forward transfer gain (or loss) of the DUT.
S21 Group Delay	The derived group delay of the forward transfer gain (or loss) of the DUT.

Raw Calibration Data – S21 ‘Through’	Raw data taken from the through connection of TRANSMIT to RECEIVE on the VNA (through the actual cables used to connect to the DUT)
S11 Magnitude as SWR	The value of S11 magnitude converted into SWR.

The following traces can be displayed in Rectangular mode, but the frequency of each point will have no relationship to the display frequency. The display shows the first 100, 200, 400, or 1020 points of the dataset in magnitude and phase rectangular format. The 1020 points of the calibration dataset start at 200 KHz and go to 120 MHz. This display is not very helpful in rectangular mode except for debugging purposes.

Et – Tracking Error compensation	A magnitude & phase plot of the amplitude and phase of the cables connecting the TRANSMIT connector of the VNA to the DUT
Es – Source Mismatch Error compensation	A magnitude & phase plot of the error due to imperfect source impedance termination.
Ed – Directivity Error compensation	A magnitude & phase plot of the error due to finite directivity in the directional coupler circuitry.
Raw Calibration Data – S11 ‘Short’	Raw data taken from the shorted load during calibration (or loaded from a calibration file).
Raw Calibration Data – S11 ‘Open’	Raw data taken from the open load during calibration (or loaded from a calibration file)
Raw Calibration Data – S11 ‘Terminated’	Raw data taken from the 50-ohm terminated load (or loaded from a calibration file).

5.5.2. Polar Display Mode

S11 (as a polar complex number) is always displayed on the Polar display. S21 cannot be displayed on the polar display. The raw calibration data (from the calibration file that is loaded) as well as the error parameters derived from the calibration data can be displayed. Normally the error compensation and raw error data are for informational purposes only and are not displayed.

The traces that can be added to the Polar mode display are:

Et – Tracking Error compensation	A complex plot of the amplitude and phase of the cables connecting the TRANSMIT connector of the VNA to the DUT
Es – Source Mismatch Error compensation	A complex plot of the error due to imperfect source impedance termination.
Ed – Directivity Error compensation	A complex plot of the error due to finite directivity in the directional coupler circuitry.

Raw Calibration Data – S11 'Short'	Raw data taken from the shorted load during calibration (or loaded from a calibration file).
Raw Calibration Data – S11 'Open'	Raw data taken from the open load during calibration (or loaded from a calibration file)
Raw Calibration Data – S11 'Terminated'	Raw data taken from the 50-ohm terminated load (or loaded from a calibration file).

5.5.3. Time Domain Reflection Mode

The TDR mode displays the real part of the Inverse Fast Fourier Transform of a reflection measurement. Because the TDR mode requires a specific custom frequency grid, it ignores the Start and Stop settings. When switching to the TDR mode, a new Frequency Grid is created. Thus, a new sweep is required. Click the sweep button. A TDR interpretation of existing S11 sweep data is not meaningful and should be ignored, instead re-acquire the reflection measurement after you have selected the TDR mode. The 'Apply Calibration' checkbox sets the reference plane for the TDR analysis. When the 'Apply Calibration' box is checked, distances specified on the TDR display are with respect to the reference plane (the end of the cable calibrated with the Short, Open, and Termination loads).

The display Start time, display Stop time, and estimated velocity factor of a cable under test are specified in the TDR Setup dialog, reached from the Vertical Display menu. Additionally, distances from the Reference Plane to the Marker point can be displayed in METERS or FEET.

The resolution of the TDR mode is 4.167 nanoseconds, it is limited by the maximum frequency that can be generated by the VNA instrument (120 MHz). It is possible to infer between TDR points by visually interpolating. For example, if two consecutive TDR points have the same large time reflection, the actual time position will lie in between those two consecutive times.

5.5.4. Choose Trace Colors

Selecting this menu item allows changing the display colors for the 6 measurement traces. Selecting a trace opens a Color dialog box allowing choice of standard or custom colors for that trace. The color changes will be saved to the configuration file when the application is closed. If no configuration file is found, or an old configuration file is loaded, then the default colors will be selected. Changes in the display color may be made to the following traces:

- S11 Magnitude Color
- S11 Phase Color
- S21 Magnitude Color
- S21 Phase Color

S21 Group Delay Color
SWR Color

5.6. Vertical Scale Menu

The Vertical Scale menu allows independently selecting the vertical scale units per division for magnitude (in dB / division), the maximum SWR display (minimum is always 1.0), the group delay (seconds per division), and the aperture size of the group delay computation.

For more information see **Appendix 4 – Group Delay and Aperture** for more details on how group delay is derived and how the data can be smoothed (or distorted) by changing the aperture size.

Note that for small frequency spans, the noise of the group delay measurements is magnified significantly due to the small difference frequency between adjacent samples. For best results, use the largest aperture window, and the largest number of gridpoints in order to reduce the measurement noise for narrow sweeps. However, large apertures may smooth the data beyond the range of interest, so care must be used to select an appropriate aperture size.

Magnitude. The display resolutions selectable are:

- 10 dB / division
- 5 dB / division
- 2 dB / division
- 1 dB / division

SWR. The display resolutions selectable are:

- SWR 1.0 to 11.0
- SWR 1.0 to 6.0
- SWR 1.0 to 3.0
- SWR 1.0 to 2.0

Group Delay. The display resolutions selectable are:

- 100 microseconds / division
- 10 microseconds / division
- 1 microsecond / division
- 100 nanoseconds / division
- 10 nanoseconds / division
- 1 nanosecond / division
- 100 picoseconds / division

Group Delay Aperture. This sets the number of adjacent frequency bins over which group delay is measured.

- Group Delay Aperture = 1
- Group Delay Aperture = 4
- Group Delay Aperture = 16

Group Delay Aperture = 64

Right Scale Display. This selects the scale printed on the right side of the rectangular display. The display values automatically adjust to the selected vertical scale factors.

- Phase
- SWR
- Delay

Polar Zoom Factor. This selects a zoom factor to be applied to the polar display. The default value is 1.0, and represents a normal polar (Smith Chart) type of display, with a reflection coefficient of 1.0 lying on the periphery of the chart. Increasing the zoom magnifies the display keeping the $50 + j0$ point (the center of the chart) in the center. Magnifying the display thus allows viewing impedances near $50 + j0$ with more resolution. A zoom factor of 2.0 places a reflection coefficient value of 0.5 on the periphery of the chart. There are four display zoom settings.

- Zoom = 1.0
- Zoom = 1.5
- Zoom = 2.0
- Zoom = 2.5

TDR Setup. This allows setting the Start Time (in nanoseconds) and the Stop Time (in nanoseconds) for the TDR display. This allows you to zoom into the area of interest. It also allows entering an estimated value of the cable velocity factor, which is used to calculate the distance from the reference plane to the marker point (perhaps a cable fault). The valid range of velocity factors is 0.4 to 0.99. It also allows selecting whether the distance display should be in Meters or Feet.

5.7. Marker Menu

The Marker menu allows setting up to five marker frequencies, and enabling or disabling the display of marker numbers and their parametric values.

Markers can also be set by *left-clicking* on the display at a frequency of interest. The first unused marker will be loaded with the frequency corresponding to the position of the mouse. If the mouse is moved before releasing the left button, the marker is *dragged* across the screen. If the left button is clicked and held on an existing marker, that marker can be dragged instead of dropping a new marker (but you have to be very accurate in pointing the mouse – especially at high display resolutions). If all markers are in use, then the left-click will not create a new one but can drag an existing one. The screen parameters update in real-time as the marker is dragged.

A value of 0 effectively disables the display of a marker (since 0 will always be off the left side of the display screen). Any marker with a value of 0 is considered

unused. It can be used by entering a displayable value in the marker entry menu. Additionally, the first unused marker will be assigned anytime the mouse is left-clicked.

The frequency of interest is readily apparent on the rectangular display, but not so on the polar display. You will however be able to see the marker move as you drag the mouse left and right. If marker parameters are enabled, you will be able to see a reading indicating the marker frequency while in the polar display mode. The marker may appear to move backwards compared to the mouse movement if the polar display is showing S11 in the lower (capacitive) half of the display. Vertical (up/down) movement of the mouse does not change the marker frequency.

The Marker parameters are color-coded to match the color of the corresponding trace on the display.

The parametric values S11, S21, and SWR are displayed only if the associated trace display is enabled.

Change Marker Frequency – Allows setting any of the five marker frequencies. A marker set to a frequency that is smaller than startFrequency or larger than stopFrequency will not display. Thus, setting a marker to zero will disable its display.

Clear All Markers – Sets all markers to zero, thus disabling their display.

Marker Numbers

Enable – displays the marker number above each marker.

Disable – turns off the marker number, showing just the markers.

Marker Parameters

Enable – displays the marker parametric value(s) underneath marker frequency.

Disable – turns off the marker parametric display.

5.8. Frequency Grid Menu

The FreqGrid menu allows selecting the number of points in the Frequency Grid. This is the number of measurements made from Start Frequency to Stop Frequency and displayed on the display. The values allowed are:

100 Points	Coarsest frequency display, but fastest acquisition of measurement data.
200 Points	
400 Points	

1020 Points	Finest frequency display, but slowest acquisition of measurement data.
-------------	--

The instrument defaults to 200 points at startup. More points allows greater resolution in the display, fewer points shortens the measurement time period. The current setting of the number of points also affects the exportation of an S-parameter text file, which will have the same number of individual frequency records as the number of points in the grid. The calibration runs are fixed in size at 1024 frequency points. When the 'Apply Calibration' box is checked, each point in the current frequency grid is interpolated to the nearest calibration frequency point, and the calibration results from that nearest point is applied to the measurement. Calibration points are about 117 KHz apart, so the nearest one is no farther than 59 KHz away. Unless the fixture has resonances (which is very bad anyway) the error due to interpolation for any size of frequency grid will be negligible except for very long cables.

5.9. Storage Menu

The Storage menu allows storing the current measurement set into temporary memory. This temporary memory will retain that measurement set until the program is terminated, or a new measurement set is stored. A new stored measurement set over-writes the existing measurements in storage.

There are three options in the Storage menu:

- Store
- Recall
- Display Storage

'Store' captures the complete raw measurement set (whether or not the traces are displayed) and stores it to memory.

'Recall' retrieves the measurement set from memory and over-writes the current active measurement set. It does not delete or alter the raw data in storage.

'Display Storage' is a toggle that is checked when the contents of storage are being displayed.

A Common use of the storage function is to make a measurement, verify it's useful, then 'store' the data. Next, some change to the device under test is made and a new measurement is made. Enabling the Display Storage option allows comparing on-screen the two measurements.

The markers are only attached to the active display set, **MARKERS ARE NOT ATTACHED TO THE STORED DATA**. This helps to distinguish which data on screen are active and which are storage. If you need to use markers on the stored data, that data should be retrieved to the active set using the 'recall' menu item.

5.10. Integration Menu

The Integration menu allows multiple sweeps of the instrument to be averaged together. The value of 1x mean no integration. The value of 2x means that the readings will average the previous sweep with the current sweep. Values of 4x, 8x, and 16x use exponential integration to average the results. This means for example, that at 16x, the scope display will be equal to 15/16 of the old display value plus 1/16 of the new value. When the Integration selection is changed, the integrator is RESET. This means that the next sweep will display the raw values from a single sweep. Subsequent sweeps will integrate. Changing the Frequency Grid size will also reset the integrator.

Resetting the integrator prevents a large offset from taking a long time to clear out of the integrated value, and can be useful when making changes to the unit under test and it is not desired to wait to see the initial results.

5.11. Help & Software Updates

The help menu launches the HTML Help viewer with the VNA help menu.

The About command opens an 'about VNA' menu. This menu displays the current build number of the software

It also contains a button to launch your Internet Browser with the address of the TAPR VNA software update website. This will display a page showing the current software available for the VNA. You can compare your build number with the latest build available number shown on the web page. Be sure to REFRESH your web browser display. If you wish, you may download the update from this page (right-click, and Save as ...)

To install the update, you will need to exit the VNA application first.

6. Controls & Screen Display

There are several controls on the VNA instrument screen. These change the start and stop frequencies, the reference and transmit signal levels, and control the sweep functions. These controls are not shown on the printed outputs.

6.1. Screen Display Size & Font Adjustment

The VNA software supports Windows display resolution and fonts size setting adjustments. These can be selected via the Windows Control panel. The

software supports the default display resolution of 96 DPI, and the alternate value of 120 DPI. Setting the display resolution to 120 DPI will expand all of the display elements, making it easier to read, but also effectively reducing the extent of the display. Selecting a larger display font may make the display easier to read.

On Windows XP, select the Display Resolution using:

- Control Panel -> Display -> Settings -> Advanced -> DPI Setting

On Windows XP, select the Display Font using:

- Control Panel -> Display -> Appearance -> Font Size

6.2. 'Uncalibrated' Indicator

The word 'Uncalibrated' will appear on screen when a condition exists that can compromise the accuracy of the measurement. Any of the following conditions will cause it to be displayed:

- The sweep speed is set to Fast.
- There is no detector calibration file loaded.
- There is no fixture calibration file loaded or it is not applied.
- The TxLevel is not set to 0 dB.

6.3. Frequency Controls

The frequency controls set the START and STOP frequencies of a sweep. The arrows increment or decrement the frequencies. The control can be set to a specific value by double-clicking the control, which will open a numeric entry dialog box allowing the desired frequency to be typed directly.

Both START and STOP controls display an underscore character underneath one of the digits. This digit is the one that will be incremented or decremented by the up or down arrows. The left and right arrow allow changing which digit position is selected. The controls will not increment above 120,000,000 Hz, nor below 200,000 Hz.

The STOP frequency must be greater than the START frequency by the size of the frequency grid. If the grid size is 400 points, for example, STOP must be at least 400 Hertz greater than START.

6.4. Level Controls

The Reference Level control adjusts how the magnitude data are displayed on the display screen. The value in the control specifies the magnitude level of the top line of the display screen. When it is set to 0 dB, the top line of the display is 0 dB. Changing the Reference Level allows you to optimize the trace location.

For example, if the DUT has an attenuation of approximately 22 dB, then it could not be displayed at a scale of 1 dB / division, because it would be off the bottom of the screen. Setting the Reference Level control to -20 dB would allow the screen to show the range of -20 db to -30 db at 1 db/division, making the trace visible.

The Reference Level control can also be set to positive values. This is useful when measuring DUT's (such as amplifiers) with output magnitudes near or above 0 dB. Note that the dynamic range of the VNA only extends a few dB above 0 dB. An external attenuator should be used if the DUT has any amount of gain.

The on-screen amplitude display values on the left-side of the display screen automatically adjust when you change the value of the reference level. It is sometimes useful to set the reference level to a small positive number when measuring a low-loss DUT to make sure the markers and marker numbers display properly.

The Transmit Level control should normally be left at 0 dBm. Decreasing the value of the control will usually degrade the dynamic range and accuracy of both the S11 and S21 measurements. However, it can be useful to reduce the drive level to a DUT that has gain. The control has about 50 dB of adjustment range, but the VNA dynamic range consumes 40 dB of that range. Thus, the S21 magnitude measurements can only effectively support less than 10 dB of level change. A much better approach is to attenuate the Transmit signal to the DUT with an attenuator. Additionally, the S11 measurements will be seriously degraded with any reduction of the Transmit level.

The magnitude values on the display automatically track changes in the Transmit Level. By the way, one valid use for the Transmit Level control is to adjust the output level when the VNA is being used as a signal generator and the measured values are of no concern. In this case, the Transmit level can be used to change the transmit output signal level over a 40 dB range.

Output levels below -10 dB are out-of-range for VNA use and result in wrong measurements, a Range Warning dialog box will pop up when trying to adjust the level below -10 dB.

6.5. Apply Calibration

The apply calibration check box is grayed-out unless a fixture calibration data set has been loaded (see calibration menu). Checking the Apply Calibration box will compensate all readings by the corrections contained in the loaded fixture calibration set. Un-checking the box disables the reading corrections. Measurements without any fixture calibration are not accurate, since there are uncompensated errors in cable length, fixture attenuation, etc. Further, some VNA instrument errors such as PC board trace lengths and amplitude variations

are not removed if the measurement is uncalibrated. For best accuracy, measurements should have fixture calibration applied.

6.6. Sweep Controls

There are three buttons on the screen that control how the VNA acquires data. These three buttons are:

- Sweep Speed
- Single Sweep
- Free-run Sweep

The Sweep Speed button determines the sweep dwell time for each measured sample, and if the VNA data are checked for measurement glitches. If set to the Fast mode, the VNA sweeps as fast as possible, and does not check the reading data for measurement glitches. As the button is successively clicked, the sweep speed will be set to the following values:

- Fast
- 30 microseconds
- 100 microseconds
- 300 microseconds
- 1 millisecond
- 3 milliseconds
- 10 milliseconds

The button recycles back to Fast after the 10 ms step. When the button displays any time value (but not Fast), more extensive comparison of the measured data is used to try and reject obviously defective individual data points (not always successfully). In the Fast mode these checks are bypassed, sometimes resulting in momentary glitches in the measured data. However, the Fast mode sweeps much faster than any of the timed modes.

The single sweep mode triggers the VNA one time, and holds the measured data after that single sweep.

The Free-run sweep button causes the VNA to trigger continuously (recurrently), so that the sweep updates as rapidly as possible. Pressing the Free-run sweep button a second time stops the recurrent sweeping. The frequency grid button is grayed-out when the VNA is sweeping, since the number of points cannot be changed during a sweep.

One very useful setup is to use a small frequency grid, for example 100 or 200 points, fast sweep mode, and recurrent sweep. This allows the display to update rapidly, and may be particularly useful when tuning a DUT such as a filter or antenna in real-time.

There is a ProgressBar for sweeps (except Fast) at the very bottom of the window. A large number of points or a very slow sweep speed can result in extremely slow sweeps. The ProgressBar helps to tell that the instrument is sweeping under very slow setting combinations.

6.7. Mouse Actions

The mouse left and right buttons can be used to perform several different actions on the screen display.

The **Left mouse button** can be clicked while in the rectangular display mode to drop a marker at the frequency where the mouse points horizontally. If the left button is held down, the marker can be dragged left and right. The marker freezes when the left button is released. An existing marker can be grabbed with the left mouse and dragged, but it takes very precise aim, and is pretty difficult to do in practice. It's usually easier to bring up the Marker menu, disable that particular marker (by entering a value of zero) and then dropping and dragging a new marker with the mouse. Alternatively, the cursor can be set coarsely with the mouse, and then the Marker Menu used to set the frequency precisely.

The **Right mouse button** provides a reading of the screen coordinates exactly where the mouse is pointing (whether or not there are any traces near the mouse). This works in both rectangular and polar modes. The popup window will stay in place until the mouse is moved a few pixels at which point it will disappear.

7. Command Line Arguments & Multiple Test Setups

Version 2 of the VNA software can be passed one command line argument that loads a specific Configuration + Measurement data set (that has been previously saved) when the application is started. Because this data set contains all of the equipment state, including a pointer to an existing calibration file, this allows different screen ICONs to invoke the VNA with different test setups. This may be useful if you have several common but different test configurations, and want to be able to select one quickly. This is equivalent to launching the program, then using File->Load Configuration + Measurement ... to load a previously saved configuration.

To pass a command line argument to the VNA application through the ICON, you will need to edit the ICON properties.

- Right click the VNAR ICON, select properties, then select the Startup page.
- Edit the TARGET to append a space and then the name of the configuration file after the last quote:

...VNAR3.exe" desired_config_filename.cfg

- Edit the name of the ICON itself on the desktop to call it something useful. You can copy and make multiple ICONs on the desktop, each with different Target string and name.
- If you don't set a command line parameter, it will work the same as Version 1.6, which loads the file "__last.cfg". This file is saved whenever the application is terminated, and contains the configuration and measurement data at the time the application was closed.

8. Example Measurement

To make a measurement of a device under test, the following general steps are used.

1. Make sure that the detector calibration has been run (you do not get the warning message on program startup).
2. Connect the cables and adaptor to be used to connect to the device under test (DUT) to the VNA.
3. Either run a Fixture calibration on these cables and adaptors, or load a previously saved fixture calibration for these exact same cables and adaptors.
4. Remove any shorts, or through connector barrels, and replace with the DUT connected from RECEIVE to TRANSMIT.
5. Run a sweep of the DUT.
6. Enable the Fixture Calibration checkbox on screen. This checkbox can be selected or deselected at any time (before or after the sweep).

Let's look at an example DUT, a low pass filter. A single sweep of data captures all the data points shown in the following three screen shots. The different screen shots are just different views of the single data set.

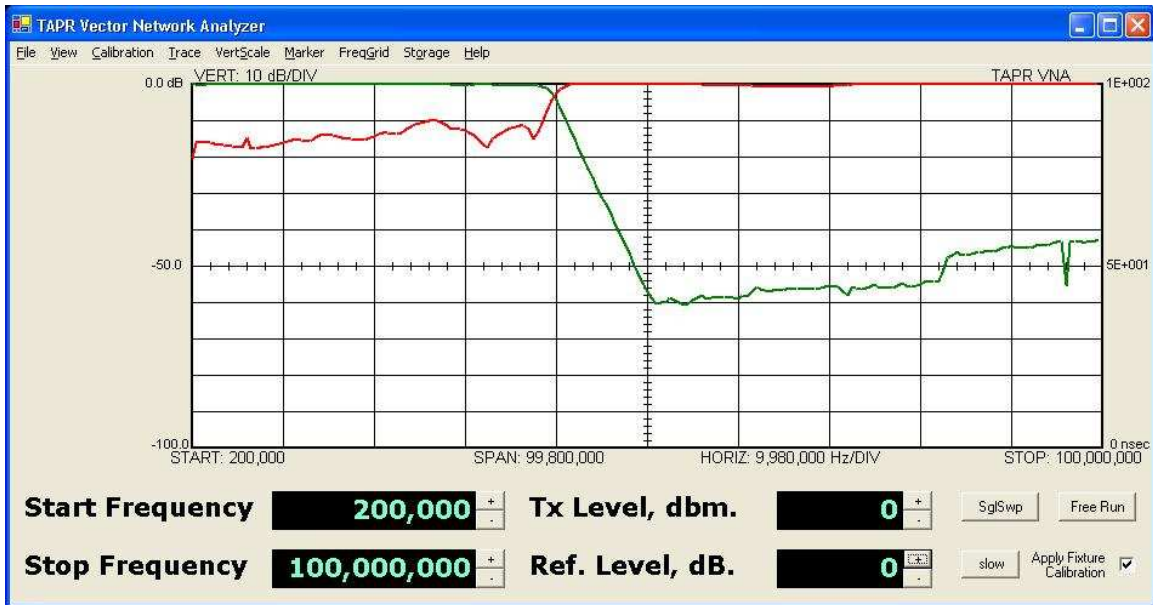

This screen shows GREEN – the S21 transfer magnitude (forward gain/loss). The screen is set for 10 dB / division. RED is the S11 return loss of the filter, again at 10 dB / division. The filter has about 60 dB loss at 50 MHz, degrading a bit at 100 MHz. The return loss of the filter is about 10-15 dB in the filter passband (200 KHZ to 40 MHz) and is 0 dB in the stopband (above 40 MHz). This type of filter is called a “reflective filter” since it generates a stopband by reflecting the input signal back.

On the next screen, the S11 (RED) trace has been turned off and only the S21 (GREEN) trace is displayed. Five markers have been set, and the display of marker parameters has been enabled. Here we can see that the insertion loss of the filter is quite good, only about 0.1 dB in the passband, and that the -3 dB frequency is about 39.85 MHz.

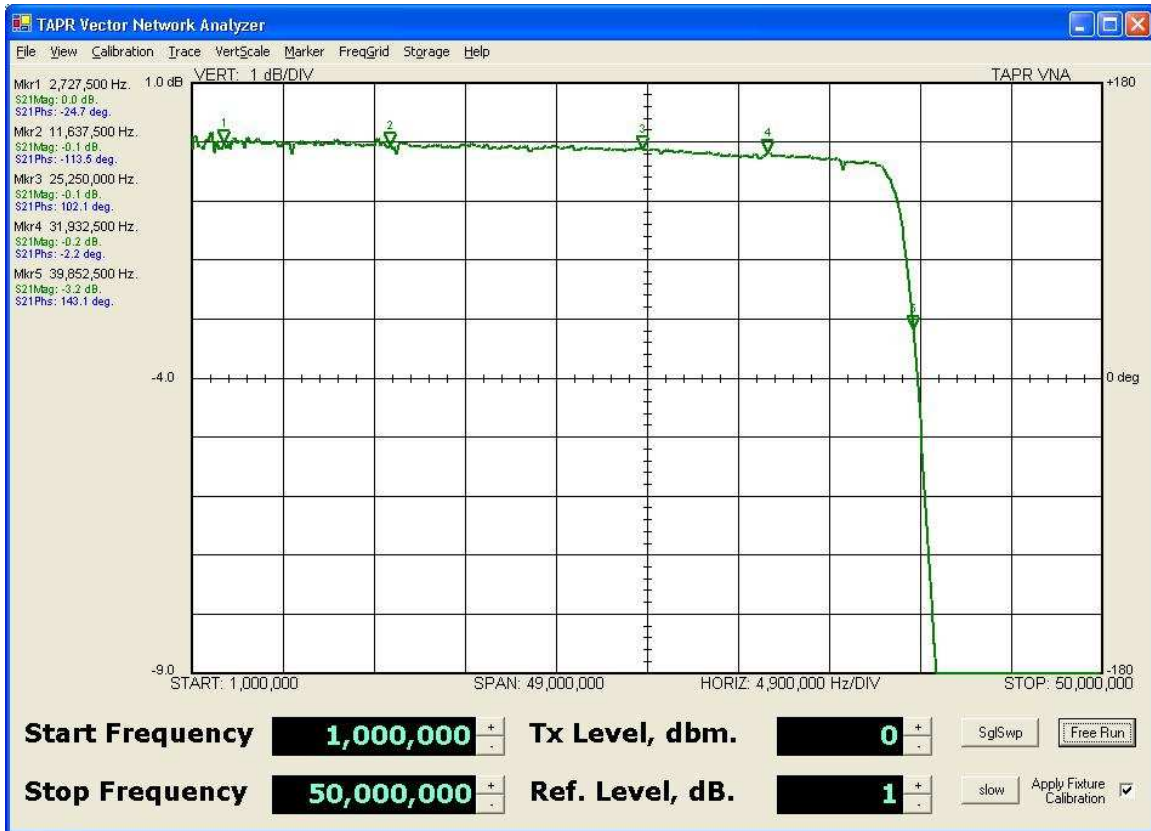

The last figure shows the input return loss (S11) on a polar chart. Four markers (which must be set in the rectangular display mode) are selected, and marker parameter display is again enabled. The markers show the input magnitude and phase as well as the equivalent input impedance of the filter at each marker frequency. The filter spirals outwards from the origin, but stays between the SWR=1.5 and SWR=2.0 concentric bull's eyes until it reaches the stopband frequency, when it rapidly spirals out of the center toward the periphery of the chart. The light gray concentric SWR circles on the polar chart are:

- SWR = 1.5 (Innermost)
- SWR = 2.0
- SWR = 3.0
- SWR = 5.0
- SWR = 10.0 (Outermost)

Due to small ripple errors in the directional coupler, the stopband return loss is calculated as negative a few tenths of a dB (which is wrong). This is shown at marker 4. The polar chart is very non-linear and changes in return loss of tenth's of a dB cause the distance from the center of the chart to change a lot when the return loss is near zero dB, but these changes are minimal when the return loss is more than a few dB.

The VNA software currently compensates for frequency dependent errors. Starting with version 1.4 the software models the coupler V/I tracking error and coupler directivity. It compensates readings by subtracting the coupler directivity and applying a sinusoidal magnitude correction vs. detected phase angle to S11 readings.

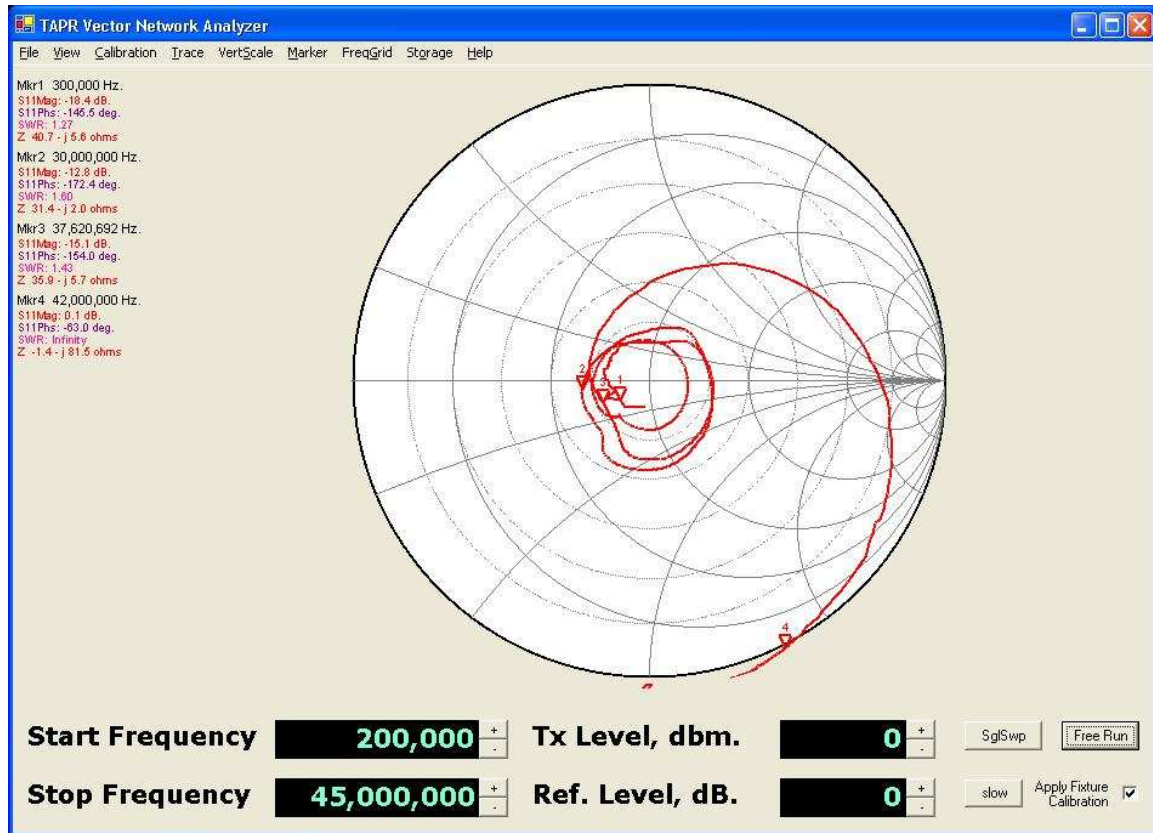

By the way, these plots are of a high-quality Bencher YA-1 low-pass-filter designed for amateur radio HF work.

8.1 Some Cautions

- High quality variable attenuators may have several tenths of a dB loss when set to the zero dB setting. This must be taken into account when characterizing filter insertion loss.
- The resistance of an attenuator may not be exactly 50.0 ohms. This will degrade the 50-ohm calibration.
- An attenuator has finite length. Thus if an attenuator is inserted (or removed) after fixture calibration, the phase angles of the setup will differ

from the Fixture correction because the distance to the 'SHORT' and 'OPEN' used for fixture calibration has changed.

- The input impedance of the VNA RECEIVE connector is only approximately 50 ohms. When measuring the return loss of a network that has minimal attenuation, the phase and amplitude components may experience errors due to this deviation of the RECEIVE connector from an ideal 50 ohm load. To improve the measurement either:
 - Terminate the unit under test with a 50 ohm termination prior to taking S11 measurements, or
 - Insert a 10 dB attenuator between the output of the unit under test and the VNA RECEIVE connector. This will assure that the device under test sees an more accurate 50 ohm termination impedance.

8.2 Common Display Results

Some common measurements will result in the displays shown in this section. These can be used to verify that you have correctly calibrated and setup the VNA and the test cables. These results are typical, but you may realize slight differences depending on the cables, instrument measurement errors, etc.

Also, there may be minor variations between consecutive instrument sweeps due to measurement variation or other artifacts. These sweeps were performed in the 'Slow' mode.

- Shorted cable – with and without cable calibration. The following charts show the polar and rectangular displays of a shorted cable on the TRANSMIT connector. The fixture calibration was performed with the same cable and short as the measurement, so the fixture and amplitude compensation should match (excepting sweep-by-sweep measurement errors, instrument temperature change, etc.).

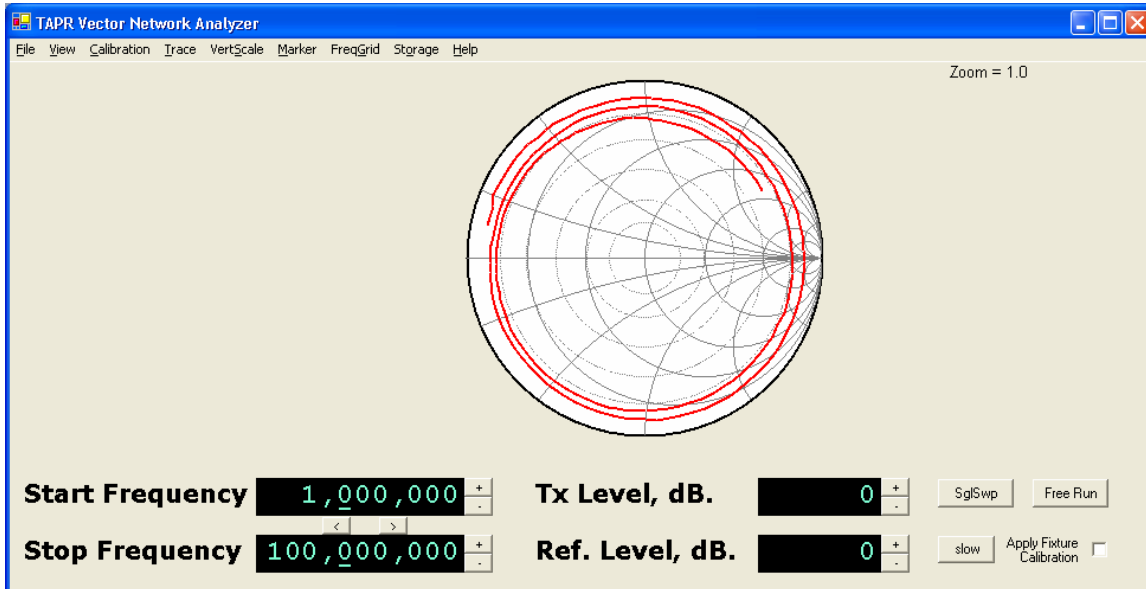

3 meter cable terminated in 'Short' without fixture calibration applied.

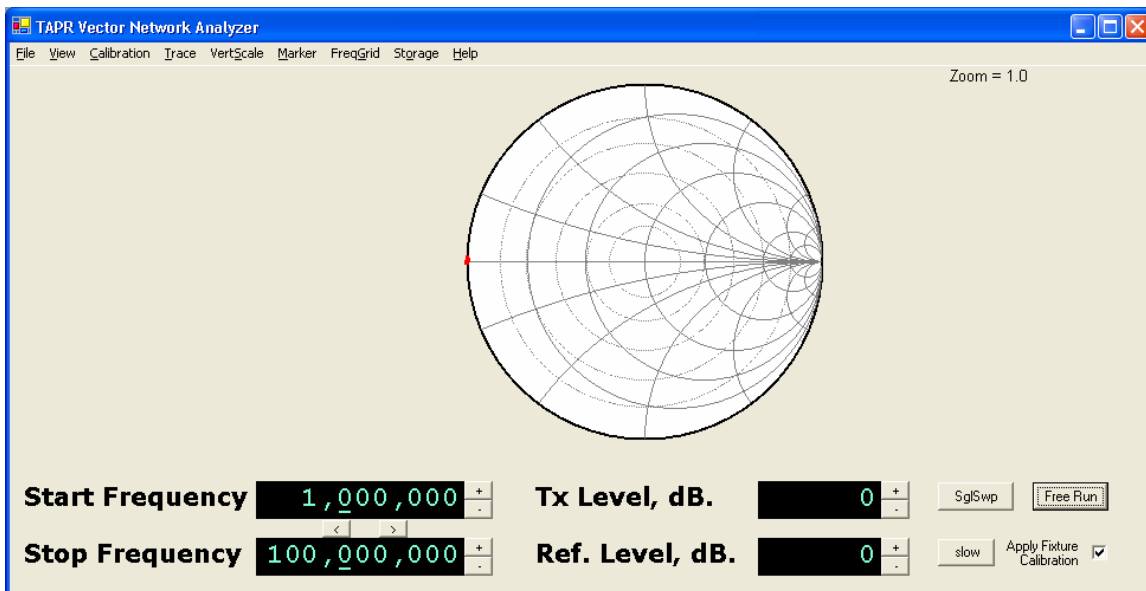

3 meter cable terminated in 'Short' with fixture calibration applied.

- Open cable – with and without cable calibration. The following charts show the polar and rectangular displays of an open cable on the TRANSMIT connector. The fixture calibration was performed with the same cable as the measurement, so the fixture and amplitude compensation should match (excepting sweep-by-sweep measurement errors, instrument temperature change, etc.).

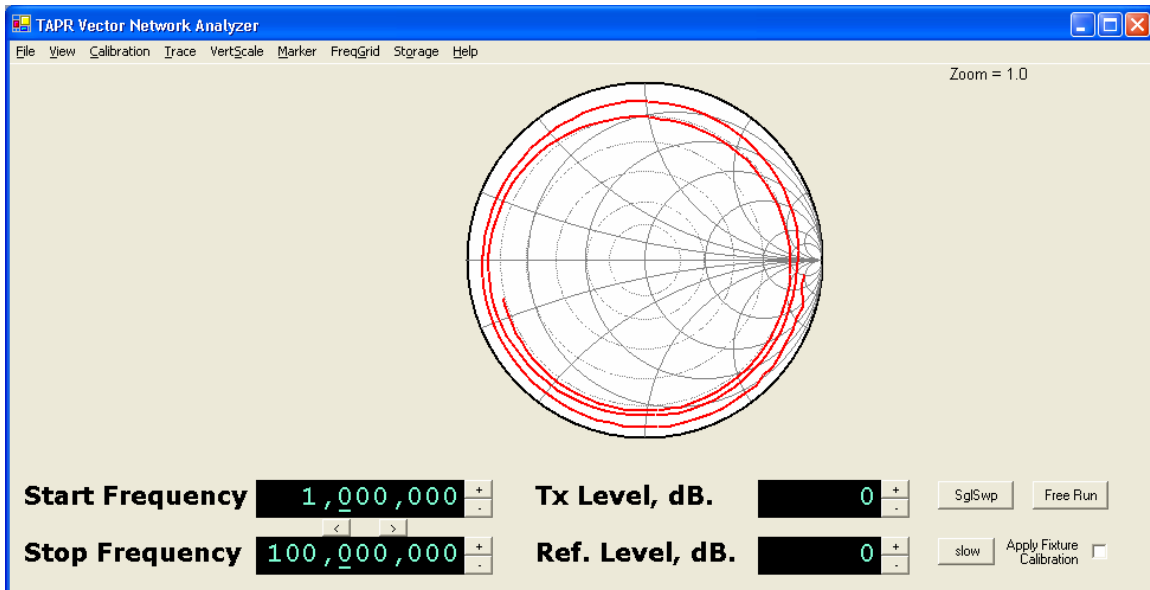

3 meter cable terminated in "Open" without fixture calibration applied.

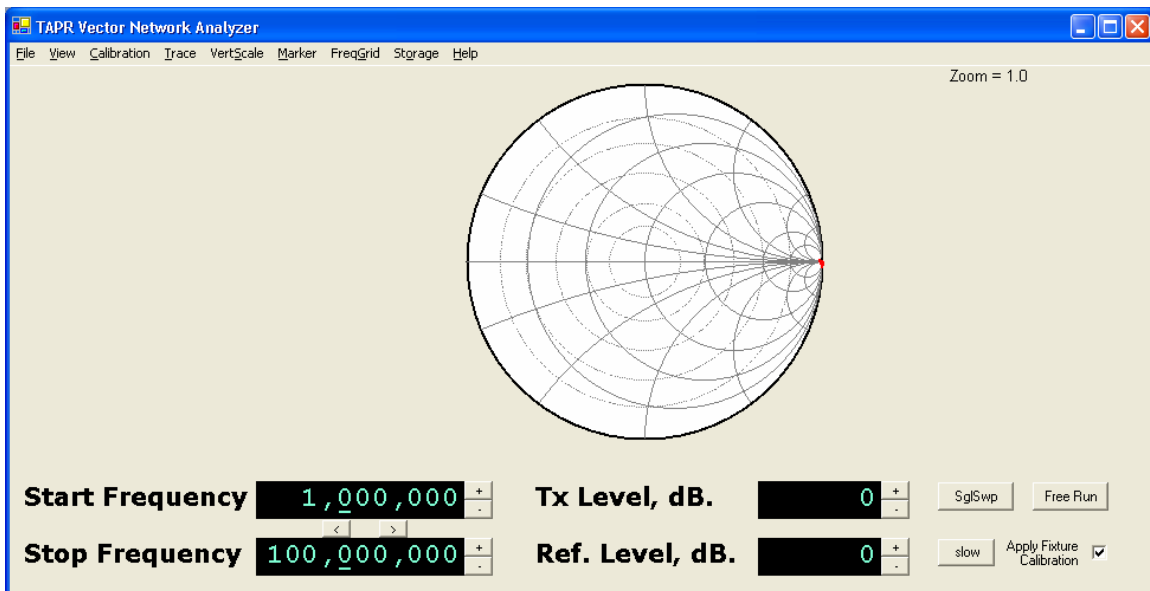

3 meter cable terminated in "Open" with fixture calibration applied.

- Terminated cable – with and without cable calibration. The following charts show the polar and rectangular displays of a reasonable quality 1 meter 50-ohm cable terminated with a 50-ohm load on the TRANSMIT connector. The fixture calibration was performed with the same cable and termination as the measurement, so the fixture and amplitude compensation should match (excepting sweep-by-sweep measurement errors, instrument temperature change, etc.). Note: many cables connected to the VNA (through a multitude of adaptors) may exhibit much poorer return loss than the example shown here.

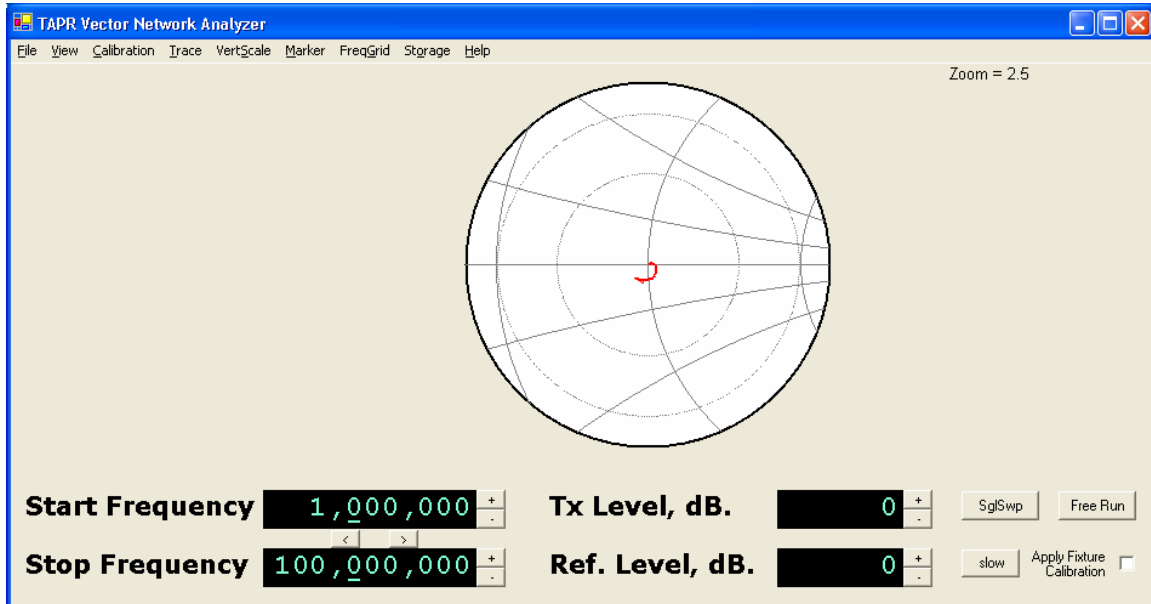

1 meter cable terminated in 50-ohm load without fixture calibration applied. The polar scale has been zoomed to 2.5:1 to show more details.

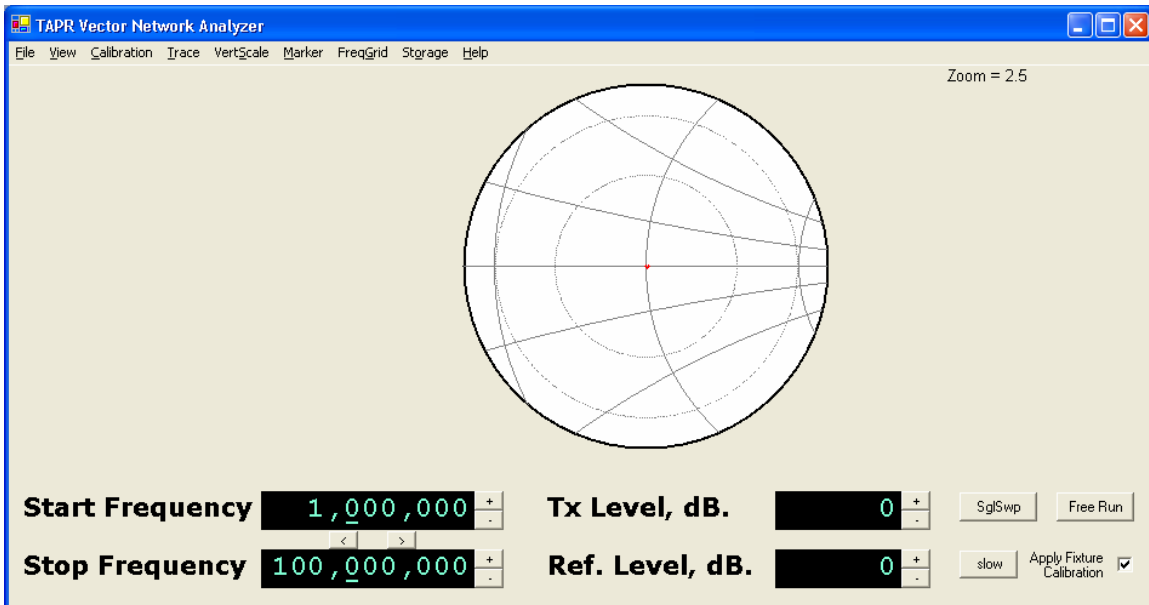

1 meter cable terminated in 50-ohm load with fixture calibration applied. The polar scale has been zoomed to 2.5:1 to show more details.

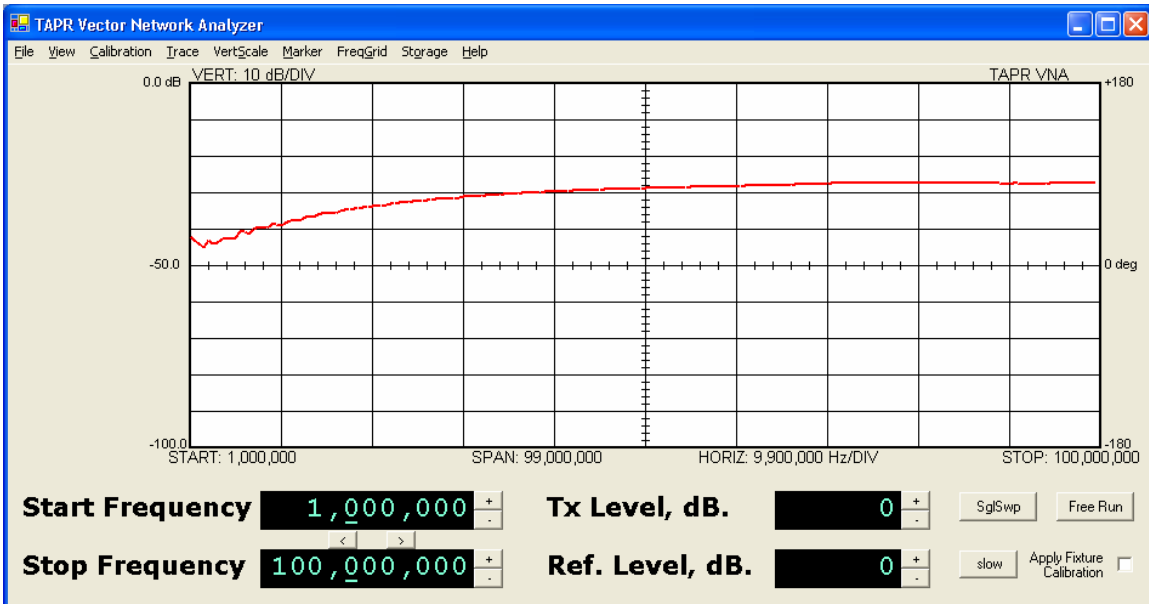

1 meter cable terminated in 50-ohm load without fixture calibration applied. Rectangular display of S_{11} .

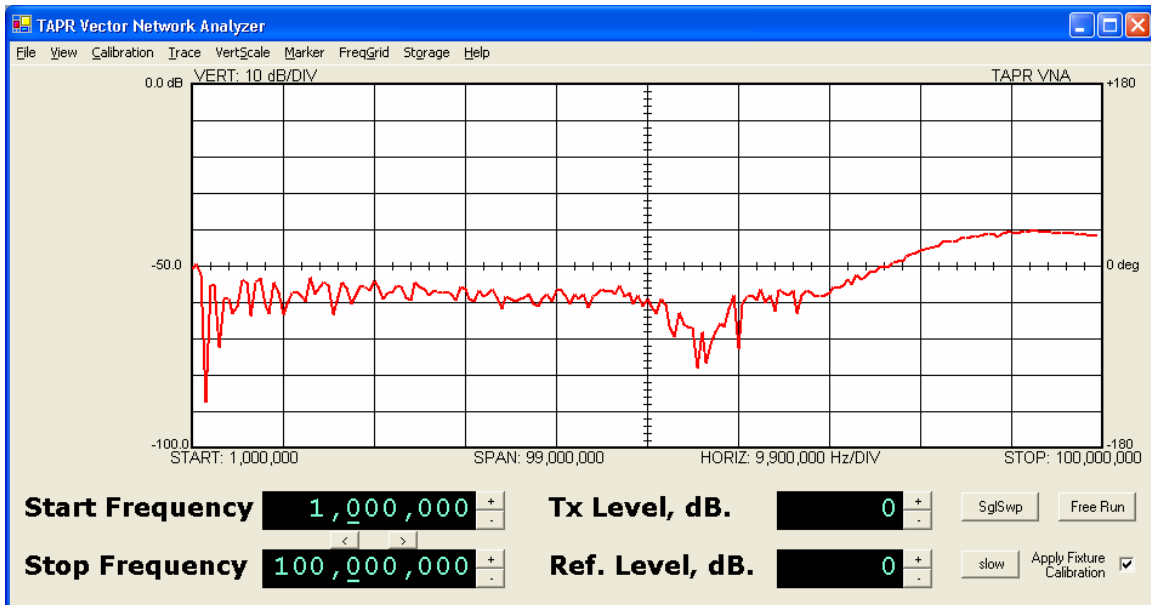

*1 meter cable terminated in 50-ohm load with fixture calibration applied.
Rectangular display of S11.*

Appendix 1 – Overview of S Parameters

This overview briefly covers the basics of reflection and transmission measurements using S-parameters, and the visualization of them on a rectangular and polar display.

A linear two port device can be characterized by the behavior of the voltage returned to voltage injected at the ports. The S-parameter model provides all the linear characteristics of a two port device at discrete spot frequencies. The S-parameters describe the input return loss, forward gain, reverse gain, and output return loss each as a complex number at a single frequency. For each discrete frequency, these 4 values describe the behavior of the two port device. To characterize a device, the S-parameters are usually measured at a number of different frequencies.

In the diagram below, a_1 is the voltage input to port one, and a_2 is the voltage input to port two; b_1 is the voltage out of port one, while b_2 is the voltage out of port two. The S-parameters are defined as the ratio of voltages. S_{11} (the input return loss) is the ratio b_1/a_1 . S_{21} (the transfer gain) is the ratio of b_2/a_1 . The voltage exiting port one of the block is the sum of the input return loss time the input voltage plus the reverse gain times the voltage injected into port two of the block. The S-parameters are defined in the following two equations:

$$\begin{aligned} b_1 &= a_1 * S_{11} + a_2 * S_{12} \\ b_2 &= a_1 * S_{21} + a_2 * S_{22} \end{aligned}$$

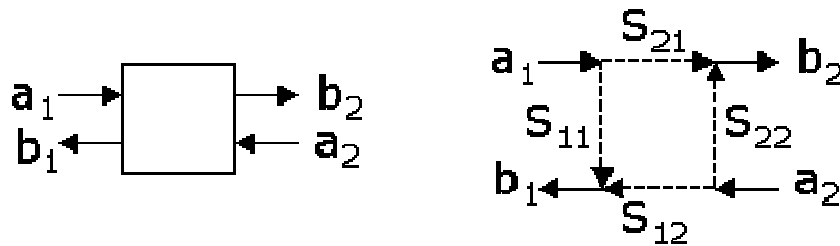

S-parameter definition

The VNA is really a transmission-reflection test set. It can launch a voltage into port one of the device (a_1), and measure the voltage received by ports one (b_1) and two (b_2). Thus, it is capable of deriving the value of S_{11} (because a_2 is zero – nothing is launched into port 2 of the block), and the value of S_{21} (similarly because a_2 is zero). In order to derive the values of S_{12} and S_{22} , the network has to be reversed in the test fixture so that ports one and two swap positions.

In general, both S_{11} and S_{21} are complex numbers – in other words, at any spot frequency the network reflects voltage back to the input, but the magnitude and the phase of the reflection are both non-zero. Similarly, the network amplifies the input power (a_1), and alters both the magnitude and phase the resultant signal (b_2). Thus the VNA measures and displays the input reflection loss and the forward transmission gain as complex numbers.

Polar Display

Since the reflection ratio (S_{11}) is always less than or equal to unity for passive networks, the value can be displayed in magnitude/phase format on a polar chart. In general, we expect the forward gain to be composed of both gain and loss values, so it may exceed unity. This makes displaying it on a polar chart difficult, since the outside circle of the polar chart constitutes a magnitude value of unity. Note that the polar chart does not have any concept of frequency. All different spot frequencies are displayed on the polar chart. The software connects the dots in order to show a line. But it's not always easy to determine what position on the line is at which frequency. The polar chart makes it easy to see what the real and reactive components of the input impedance are at any point. Thus, the polar chart makes the visualization of the important characteristics of S_{11} very easy.

The polar value of S_{11} is plotted directly on the polar chart, with the S_{11} vector beginning at the center of the chart, the length of the vector being the magnitude of the return loss, and the direction of the vector being the phase angle of S_{11} .

The left side of the chart corresponds to a direction of +180 or -180 degrees, and is the low-impedance area of the chart. The right side of the chart corresponds to a direction of 0 degrees, and is the high-impedance area of the chart.

Rectangular Display

It is also possible to display the S11 and S21 values on a rectangular display. In this case, the magnitude of the return loss is displayed vs. frequency. This makes it easy to read how large the return loss is at any given frequency, but it's difficult to understand how reactive or resistive the input impedance really is. In contrast, we don't usually care too much about the transfer impedance of a network, but we do care about its gain vs. frequency, and its phase delay vs. frequency. The rectangular chart makes the visualization of the important characteristics of S21 very easy.

The magnitude of the return loss of the transfer gain/loss of the network is expressed in dB on the right side of the rectangular chart. The phase of the return loss or the phase of the transfer gain is plotted as degrees vs. frequency. The top line of the rectangular chart is +180 degrees, while the bottom line is -180 degrees. The rectangular chart 'wraps around' from the bottom to the top because a phase angle of -180 degrees is the exactly the same as a phase angle of +180 degrees. Thus the top line and the bottom line of the rectangular chart represent precisely the same phase value.

This causes a confusing display when the phase value is 180 degrees, but varies a few tenths of a degree above and below the value 180.0. It would normally be a straight line, but the rectangular display will show it as a trace that varies wildly up and down the screen, first close to the top line, then alternatively at the bottom line, and then back again at the top line.

Group Delay

Sometimes it's desirable to know the time delay properties of a network. The group delay of a network is the negative of rate of change of phase with respect to frequency. Group delay is sometimes useful in determining the electrical length of a network such as a cable or stub. The electrical length of a cable usually differs from the physical length due to the velocity factor of the cable. Thus, the group delay computation, along with a physical measurement of the cable length allows computing the velocity factor of a cable.

The phase velocity of a cable is simply the time delay of the speed of light traveling the length of the cable divided by the actual time delay of the cable. Suppose a 10 foot piece of cable has a measured delay of 15 nanoseconds. The speed of light is 11.8 inches per nanosecond (very close to 1 nanosecond per

foot). Ten feet of free space would have a light speed delay of $120/11.8 = 10.17$ nanoseconds. Thus the velocity factor of this cable would be:

$$\frac{10.17 \text{ nanoseconds (free space delay)}}{15 \text{ nanoseconds (measured delay)}}$$

or a value of 0.68.

SWR

The SWR of a network at any specific frequency is a description of how well the network input looks like a 50 ohm non-reactive load when the output of that network is terminated in 50 ohms. An SWR of 1.0 means that the network has exactly a 50-ohm input impedance. SWR is directly related to the magnitude of the input return loss. SWR ignores the phase angle portion of the input reflection, so it is a real number whereas S11 is a complex number (containing both the magnitude and phase angle of the input return loss).

An SWR of 2.0 means that the input impedance is either 25 ohms resistive, 100 ohms resistive, or some complex value ranging between those two impedances, and containing non-zero reactance. The value of SWR does not tell us which of these cases the network looks like, whereas S11 does.

On the polar chart, each constant value of SWR describes any impedance lying on a circle centered on the center of the polar chart. The center of the polar chart is $50+j0$ ohms, an SWR of 1.0 (the circle is a point). Higher values of SWR produce circles of increasing radius centered on the chart center point. An SWR value of infinite is a circle lying at the outside periphery of the polar chart.

The following table relates the SWR to the magnitude of the input return loss.

SWR	Return Loss, dB.
1.00	infinite
1.03	36.60
1.05	32.25
1.10	26.45
1.15	23.12
1.20	20.83
1.30	17.70
1.40	15.56
1.50	13.98
1.60	12.74
1.70	11.73
1.80	10.88
1.90	10.16

2.00	9.54
2.50	7.36
3.0	6.02
4.0	4.44
5.0	3.52
10.0	1.74
20.0	0.87
infinite	0.00

Appendix 2 – Calibration Details

Detector Calibration

The detector calibration routine applies a range of signals from approximately 0 dBm down to -90 dBm to each magnitude detector (transmission and reflection). It does this repeatedly over the range 200 KHz to 120 MHz. The calibration software models each detector response function (voltage vs. level) at each frequency. The model consists of a linear portion and noise floor portion. The software models the linear portion by generating a linear least-squares regression estimator for amplitude measurements, and a correlation coefficient. Then it generates an empirical exponential estimator for the noise floor that allows a smooth curve to be fit to the complete linear + noise floor response.

The detector calibration routine similarly characterizes both phase detectors. The phase calibration process is a bit more complex than the amplitude calibration process. It uses a fixed length of cable and a varying frequency to develop a linear frequency-dependent phase excitation to the detectors. Then it finds the proper voltage levels that are output by the phase detectors corresponding to -180, 0, and +180 degrees (the positive peak, midpoint, and negative peak voltages respectively). The phase detectors have a periodic error component, and the detector calibration routine uses a linear delay model to build a table to correct those periodic errors.

All the various data sets are then saved in the file 'detector.ica' in the VNA program startup directory.

Fixture Calibration

S21 Compensation

The Fixture calibration routine measures the received signal through a small bullet or barrel connector. It measures the received magnitude and phase at 1024 points across the range 200 KHz to 120 MHz and stores all the data in a table in the Fixture calibration file (which you name during the Fixture calibration save operation). The calibration compensation routine divides the S21 actual measurement by the nearest 'Through' calibration constant (which is a complex number) at each different measurement frequency when the 'Apply Calibration' box is enabled.

S11 Compensation

The calibration compensation for S11 derives three parameters of a virtual S-parameter error matrix computationally inserted between the VNA TRANSMIT connector and the DUT. With three measurements and three unknowns, the

values of the virtual S-parameter error matrix can be resolved. These three parameters are:

- Et – the tracking error. This is (S21error * S12error) product of the virtual error matrix.
- Ed – the directivity error. This is S11error of the virtual error matrix.
- Es – source impedance mismatch. This is the S22error of the virtual error matrix.

The virtual error matrix is removed from the S11 measurement (when 'Apply Calibration' is active) to compensate for these errors in reflection measurements.

Fixture Calibration Data Set

The following data are included in the fixture calibration data set. Values can be viewed (for those who are curious) from the **Trace** menu. The Polar display only displays reflection measurements (S11) and related raw and derived calibration constants. The rectangular display can show both S11 and S21 measurements, and the calibration constants related to S21.

Et – Tracking Error compensation	A complex plot of the amplitude and phase of the cables connecting the TRANSMIT connector of the VNA to the DUT
Es – Source Mismatch Error compensation	A complex plot of the error due to imperfect source impedance termination.
Ed – Directivity Error compensation	A complex plot of the error due to finite directivity in the directional coupler circuitry.
Raw Calibration Data – S11 'Short'	Raw data taken from the shorted load during calibration (or loaded from a calibration file).
Raw Calibration Data – S11 'Open'	Raw data taken from the open load during calibration (or loaded from a calibration file)
Raw Calibration Data – S11 'Terminated'	Raw data taken from the 50-ohm terminated load (or loaded from a calibration file).

Appendix 3 – Software Installation, Registry

When you apply power to the VNA and first attach it to the computer via its USB cable, its USB device ID will not be found. The New Hardware Detected wizard will be invoked and will ask if a disk or file is available for the new device. The file it is looking for is `usbw2k.inf`. This is installed in the INF directory by the installer. So, you should allow windows to search for the file by itself (the *recommended* option presented). The correct device type is:

```
Cypress EZ-USB (2131Q/2131S/2135S) - EEPROM missing
```

The wizard will create a registry key that associates the USB vendor and product ID to the `ezusb.sys` driver. This provides the linkage between the USB device ID and the correct device driver. In the future when this USB device is plugged into the host, it is not necessary to go through the selection process again.

The Cypress AN2135 uses the following USB IDs:

```
Vendor_ID: 0547
Product_ID: 2131
```

The software installation makes a registry entry in order to associate the device drive for the Cypress EZUSB device with the driver needed to communicate with it (`ezusb.sys`). This registry can be removed (but does not need to be removed) if it the VNA software is uninstalled. Normally the registry key is left in place, but if for some reason you would like to delete after a software uninstall, it can be deleted with Regedit.

Different versions of windows have different Registry directory structures, and the keys are placed in different locations.

- You can delete the Registry key associated with this particular USB device (VID 0547, PID 2131), in which case the next time it is plugged in, the new hardware detected wizard will run.
- If you delete the Registry key, you should also delete the file `ezusbw2k.PNF` located in the `WINDOWS\INF` directory.

Version	Registry Key Location
Win98, ME	\HKEY_LOCAL_MACHINE\Enum\USB
WinNT, 2000, XP	\HKEY_LOCAL_MACHINE\SYSTEM\CurrentControlSet\Enum\USB

Appendix 4 – Group Delay and Aperture

Group Delay is an equivalent time delay through a device or network. Mathematically, it is defined as the negative of the rate of change (the slope) of phase vs. frequency:

$$\text{GroupDelay} = -\frac{d\phi}{d\omega}$$

In the VNA, a measurement sweep consists of a number of individual discrete data points taken at single spot frequencies. Thus, the group delay is calculated by looking at two adjacent frequency samples – the current sample, n and the next sample, $n+1$, being taken at frequencies f_n and f_{n+1} . The difference in phase is calculated by subtracting the phase reading taken at frequency f_n from the phase reading taken at frequency f_{n+1} . The delay is then calculated by converting degrees into radians and the sign is changed. Unfortunately, this finite difference process can result in a large amount of noise in the reading, due to small errors in the measured phase, or from actual noise in the measurements.

One way to reduce the noise on the display is to average the group delay readings over a number of samples. This delay reading is less noisy, but it may miss some important rapid changes in the phase response. Thus the VNA allows selecting how large this averaging function is. The number of samples included in the average is known as the *aperture* size of the measurement.

An aperture size of 1 means that there is no averaging, and the measurement is taken between two adjacent frequency samples. The aperture frequency window is thus $f_{n+1} - f_n$.

An aperture size of 64 means that the delay is calculated by subtracting the phase measured at frequency sample f_{n+32} from the phase measured at frequency sample f_{n-32} . Thus the reading spans 64 frequency differences (65 samples). One drawback to this averaging technique is that the phase could change through several 360 degree rotations between f_{n-32} and f_{n+32} . This would result in the group delay calculation being far less than the real group delay since the VNA cannot resolve phase changes exceeding 360 degrees. Thus aperture should be used with appropriate caution.

Aperture Shortening

In the VNA software, the aperture window concept runs into another difficulty and that is calculating the aperture window for samples near the start frequency and near the stop frequency. In the case of the start frequency, there are no samples below the current measurement frequency f_n thus the VNA does not have a value of phase taken at a frequency less than f_n . In the case of an aperture window of

64, the software *shortens* the effective aperture window by using f_n and f_{n+32} (rather than f_{n-32} and f_{n+32}). Thus the effective aperture is 32 (not 64). The same shortening happens at the stop frequency because there are no samples taken at a frequency greater than f_n .

The software similarly shortens the aperture window for frequency samples between the start frequency and the mid point of the aperture, but by a lesser amount for each higher frequency sample. Once the 32nd frequency sample above the start frequency is reached, all points necessary for a 64-point aperture are present, and the aperture window is no longer shortened. Similarly, the aperture window remains at 64 through the 32nd frequency below the stop frequency is reached, when the window must then be shortened.

For aperture sizes of 4 and 16, the worst case shortening is to an effective aperture size of 2 samples, and 8 samples, respectively near the start and stop frequencies.